



# IRONWOOD

IN NORTH OSHAWA





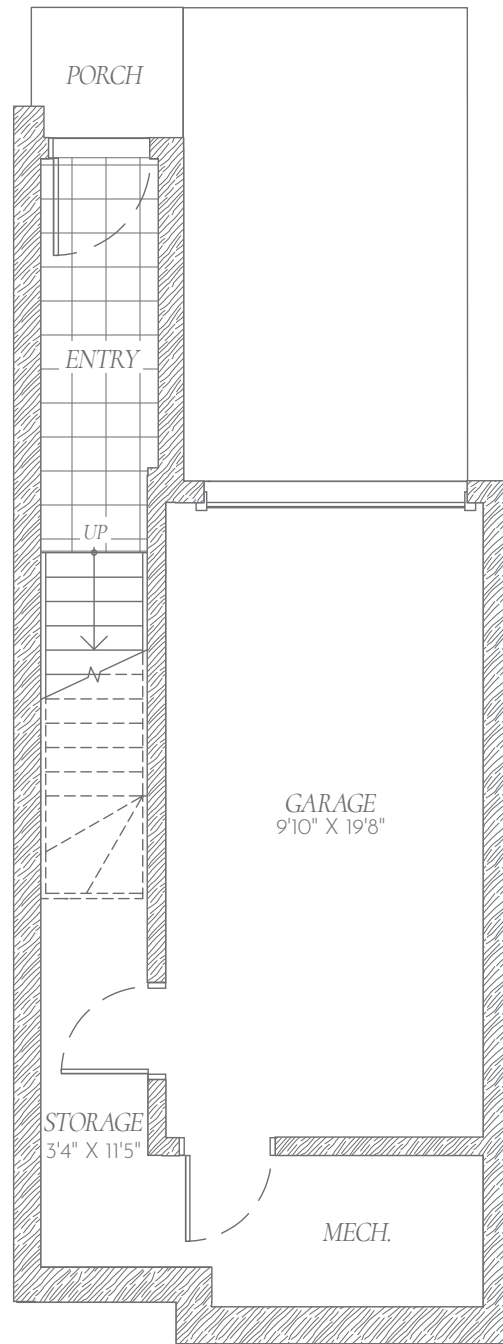

**BASEMENT**

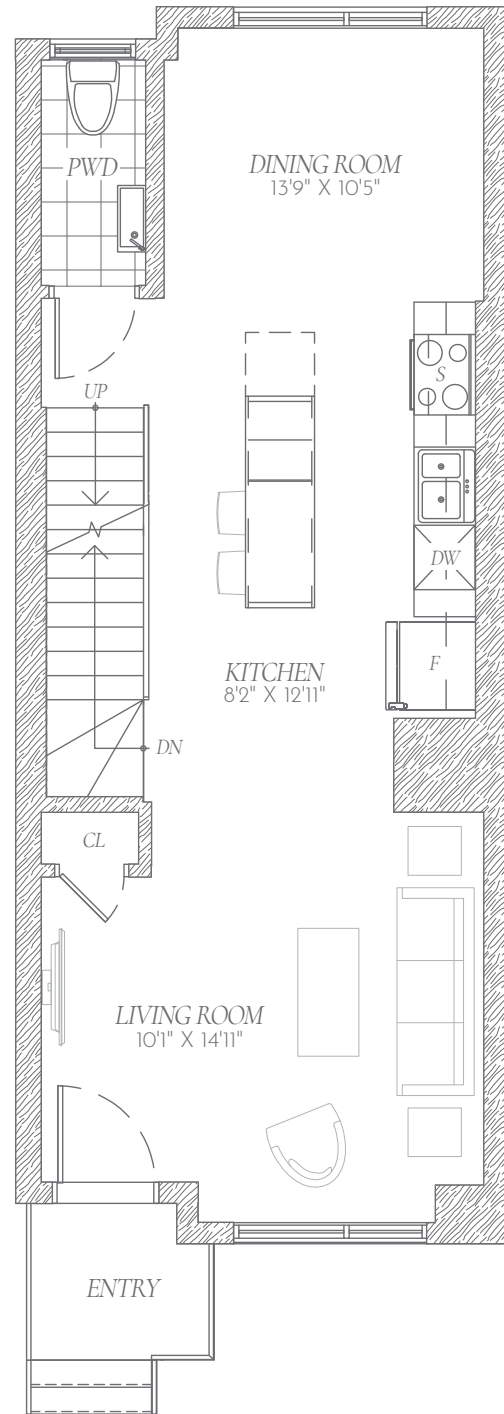

**FIRST FLOOR**

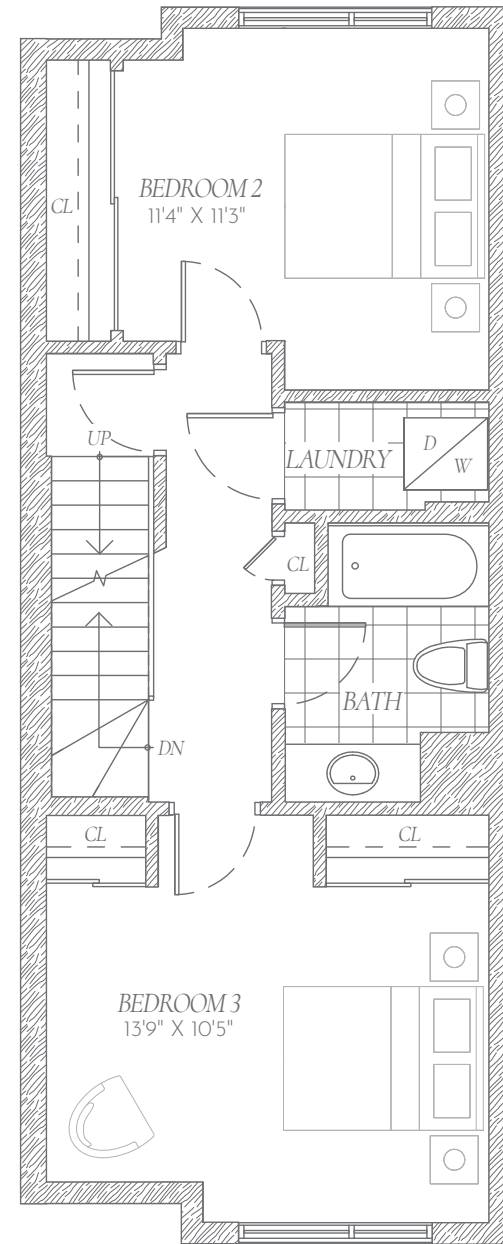

**SECOND FLOOR  
OPT. 1**

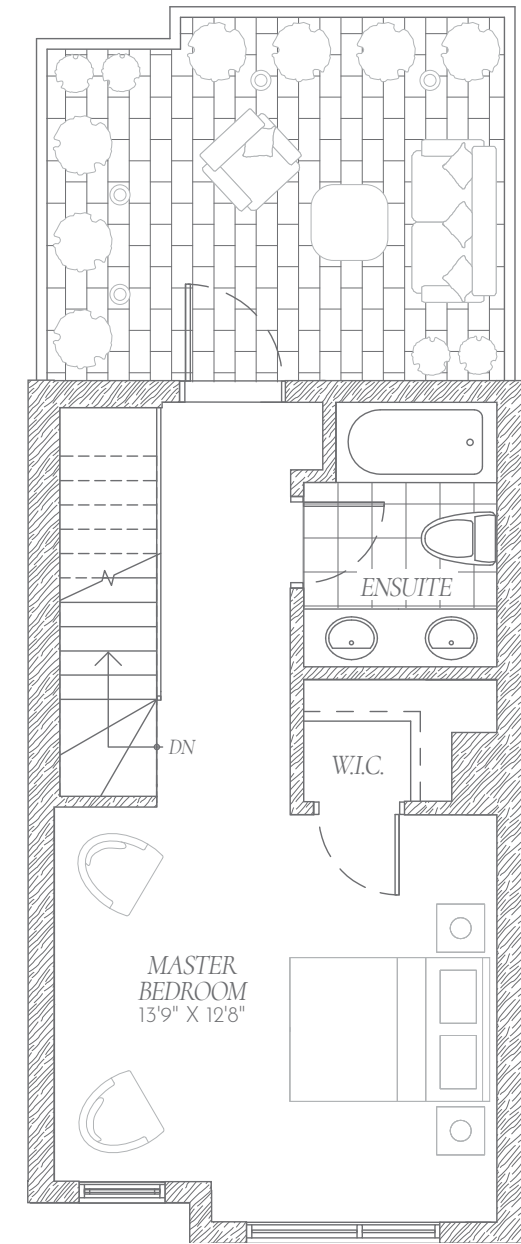

**THIRD FLOOR  
OPT. 1**

# THE TWEED SPECIAL

STANDARD: MASTER BED - LEVEL 3

## 1,646 SQ.FT.

TWEED SPECIAL END UNIT • 1,698 SQ.FT.  
TWEED SPECIAL CORNER UNIT • 1,698 SQ.FT.



All floor plans, elevations and site plan are artist's concept only. Specifications and landscaping are subject to change without notice. Note that floor plan layouts and room dimensions may vary according to elevation. All backyards and driveways are conceptual only and are subject to actual POTL. Drawing is not to scale and all dimensions are approximate. Actual usable or space may vary from the stated floor area. Purchaser(s) acknowledge and agree to accept a reverse layout (mirror image) of all floor plans and elevations which the Developer or Municipality may require.

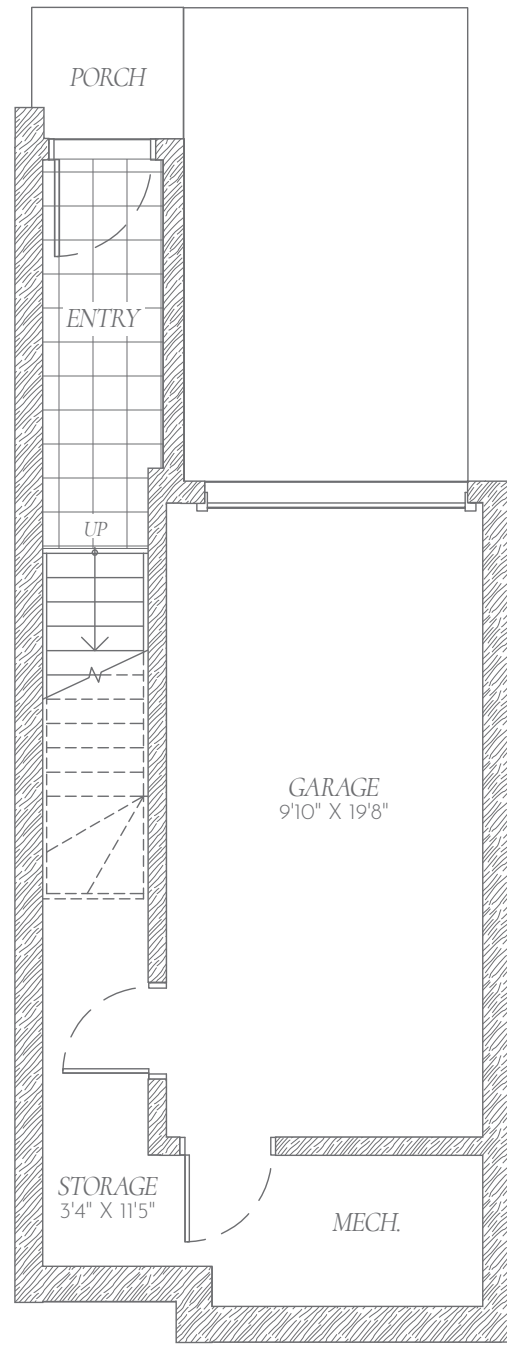

**BASEMENT**

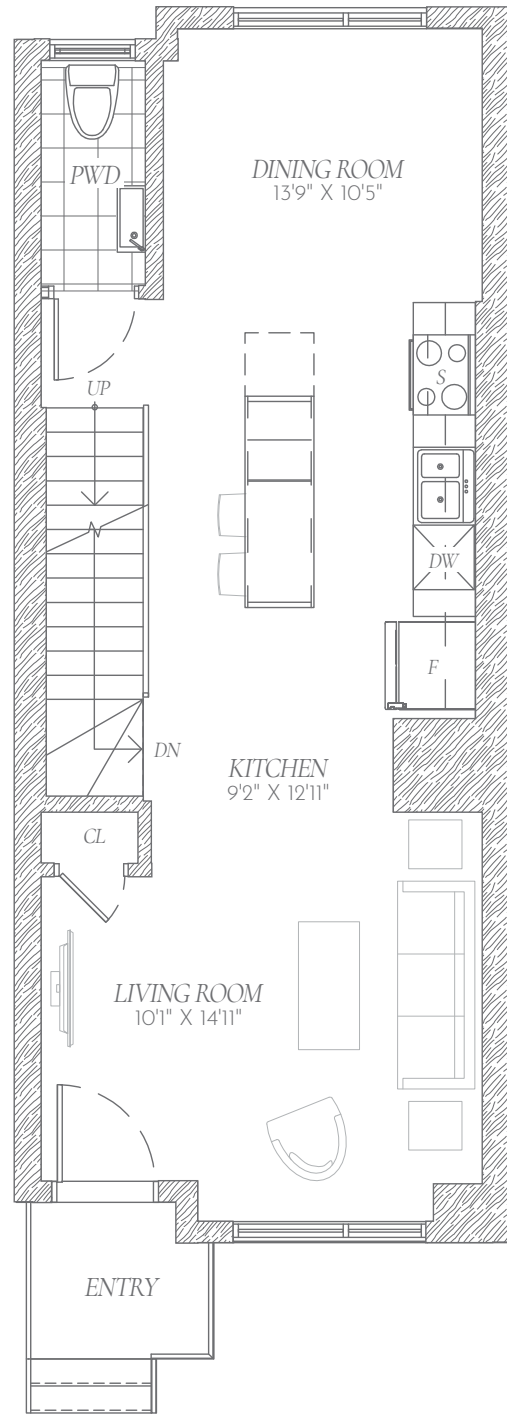

**FIRST FLOOR**

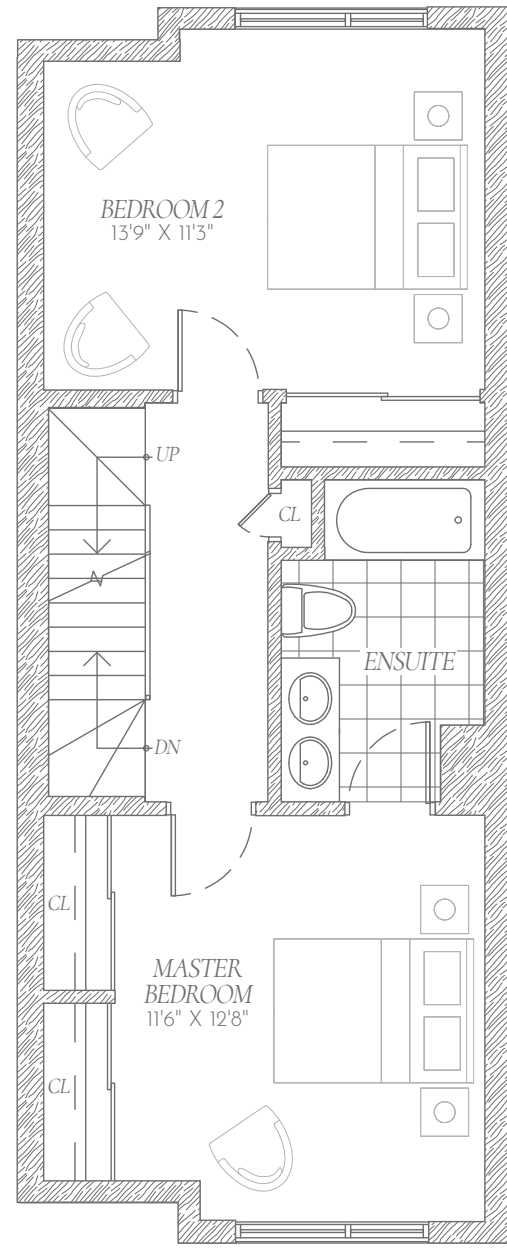

**SECOND FLOOR  
OPT. 1**

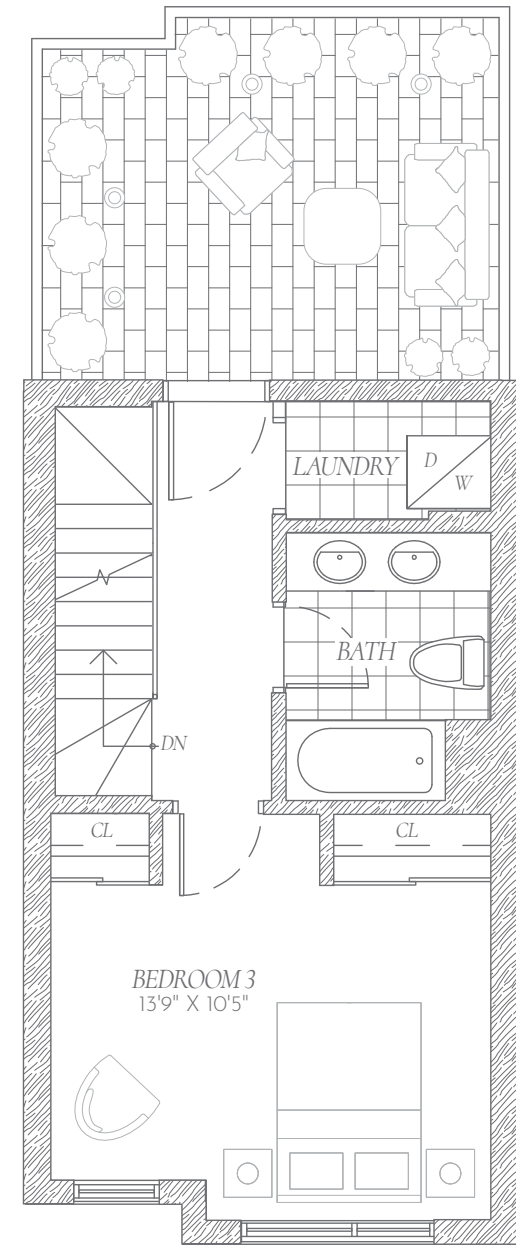

**THIRD FLOOR  
OPT. 1**

# THE TWEED SPECIAL

UPGRADE: MASTER BED - LEVEL 2

## 1,646 SQ.FT.

TWEED SPECIAL END UNIT • 1,698 SQ.FT.  
TWEED SPECIAL CORNER UNIT • 1,698 SQ.FT.



All floor plans, elevations and site plan are artist's concept only. Specifications and landscaping are subject to change without notice. Note that floor plan layouts and room dimensions may vary according to elevation. All backyards and driveways are conceptual only and are subject to actual POTL. Drawing is not to scale and all dimensions are approximate. Actual usable or space may vary from the stated floor area. Purchaser(s) acknowledge and agree to accept a reverse layout (mirror image) of all floor plans and elevations which the Developer or Municipality may require.

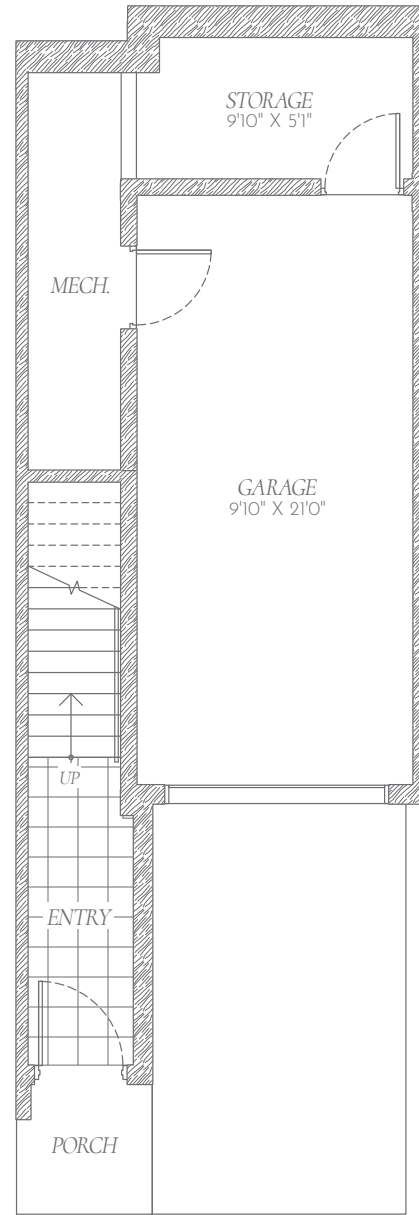

**BASEMENT**

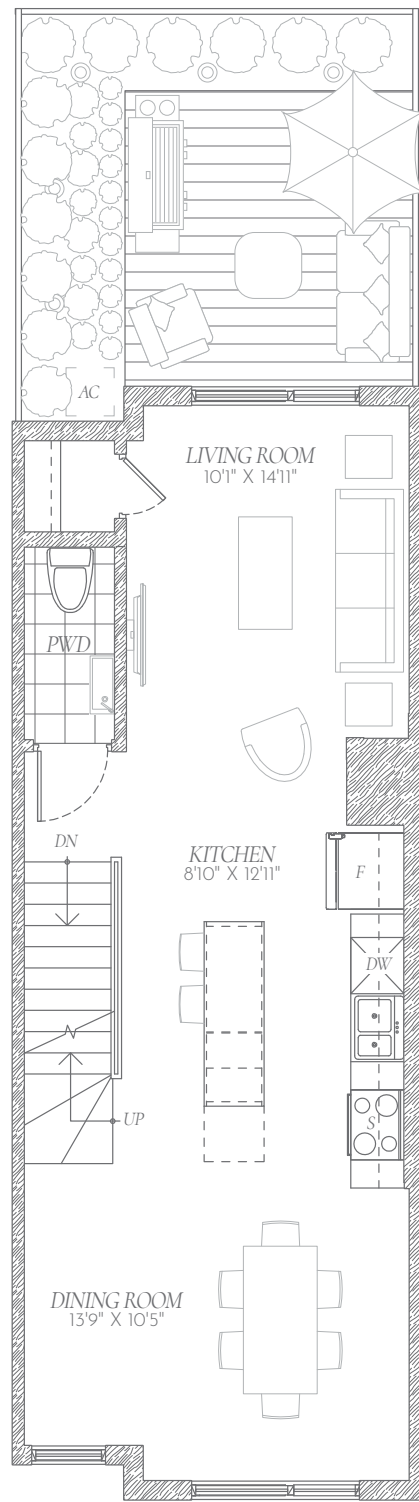

**FIRST FLOOR**

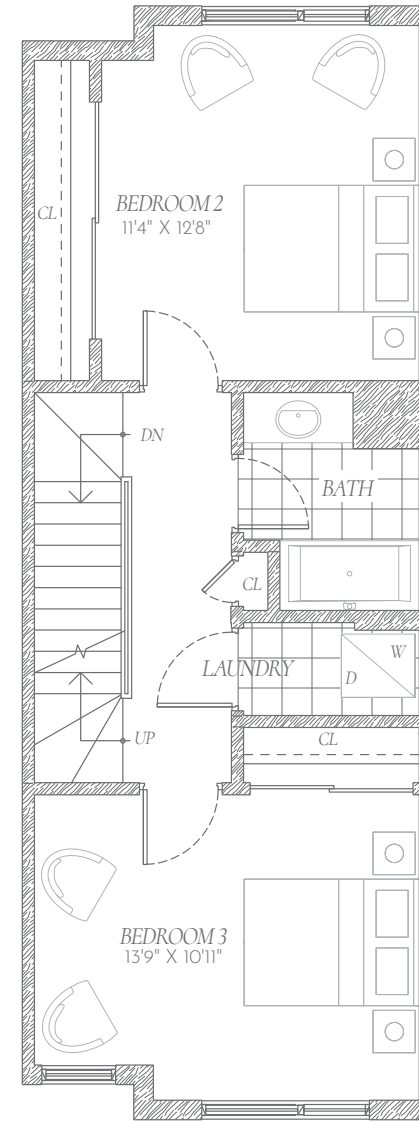

**SECOND FLOOR  
OPT. 1**

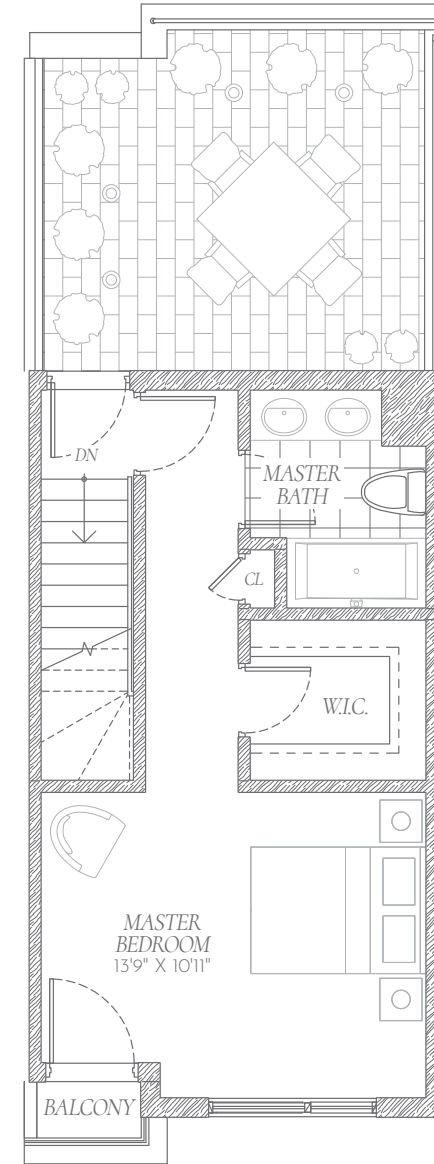

**THIRD FLOOR  
OPT. 1**

# THE HOUNDSTOOTH SPECIAL 1,572 SQ. FT.

STANDARD: MASTER BED - LEVEL 3



HOUNDSTOOTH SPECIAL END UNIT • 1,628 SQ.FT.  
HOUNDSTOOTH SPECIAL CORNER UNIT • 1,641 SQ.FT.

All floor plans, elevations and site plan are artist's concept only. Specifications and landscaping are subject to change without notice. Note that floor plan layouts and room dimensions may vary according to elevation. All backyards and driveways are conceptual only and are subject to actual POTL. Drawing is not to scale and all dimensions are approximate. Actual usable or space may vary from the stated floor area. Purchaser(s) acknowledge and agree to accept a reverse layout (mirror image) of all floor plans and elevations which the Developer or Municipality may require.

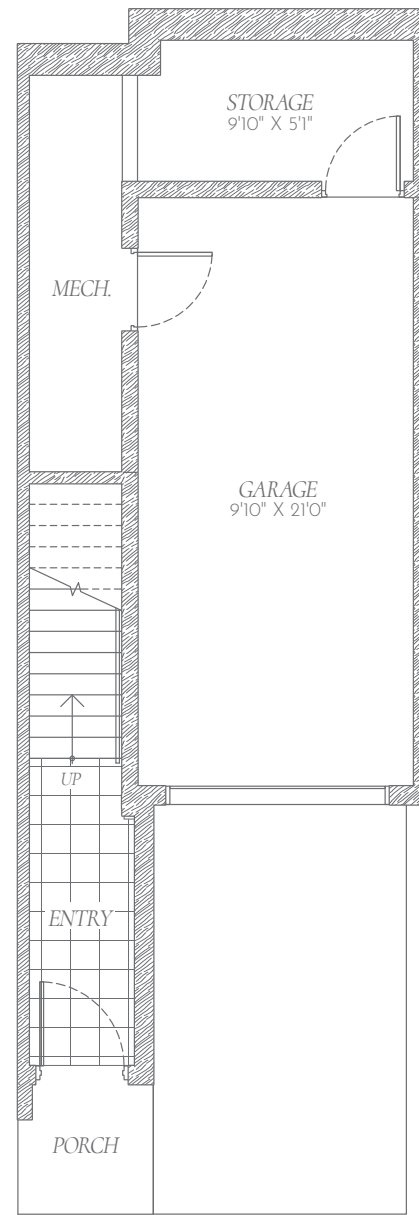

**BASEMENT**

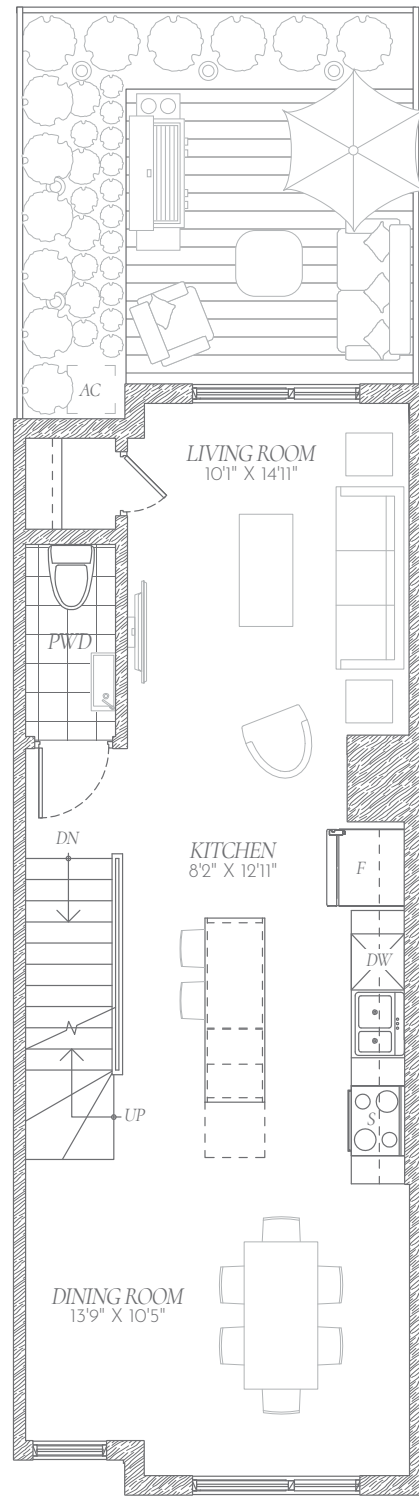

**FIRST FLOOR**

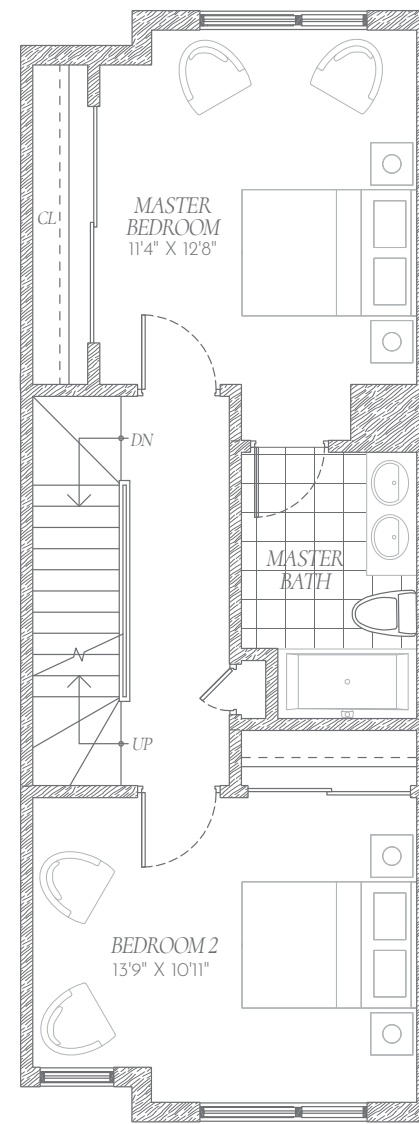

**SECOND FLOOR  
OPT. 2**

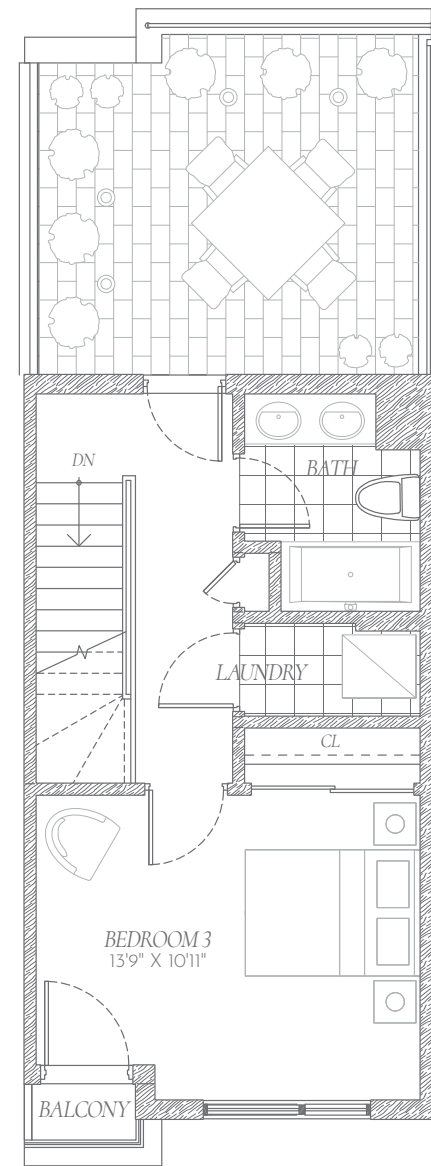

**THIRD FLOOR  
OPT. 2**

# THE HOUNDSTOOTH SPECIAL 1,572 SQ. FT.

UPGRADE: MASTER BED - LEVEL 2

HOUNDSTOOTH SPECIAL END UNIT • 1,628 SQ.FT.  
HOUNDSTOOTH SPECIAL CORNER UNIT • 1,641 SQ.FT.



All floor plans, elevations and site plan are artist's concept only. Specifications and landscaping are subject to change without notice. Note that floor plan layouts and room dimensions may vary according to elevation. All backyards and driveways are conceptual only and are subject to actual POTL. Drawing is not to scale and all dimensions are approximate. Actual usable or space may vary from the stated floor area. Purchaser(s) acknowledge and agree to accept a reverse layout (mirror image) of all floor plans and elevations which the Developer or Municipality may require.

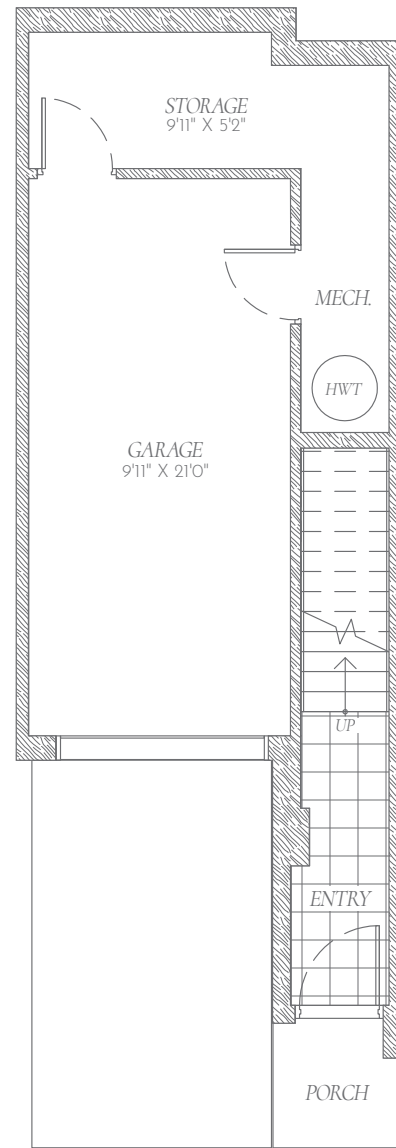

**BASEMENT**

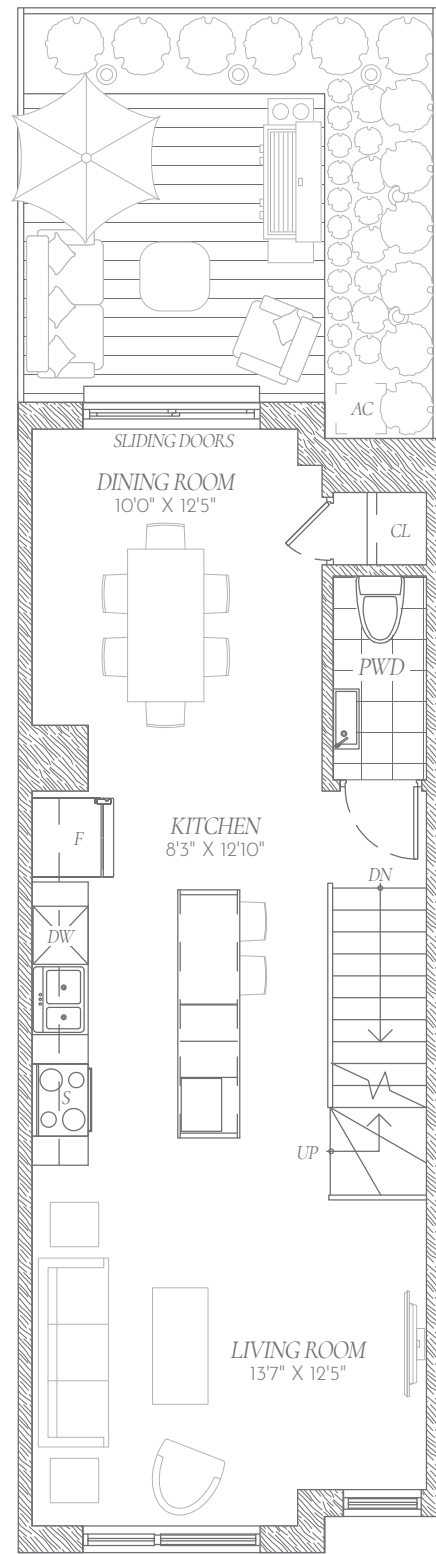

**FIRST FLOOR**

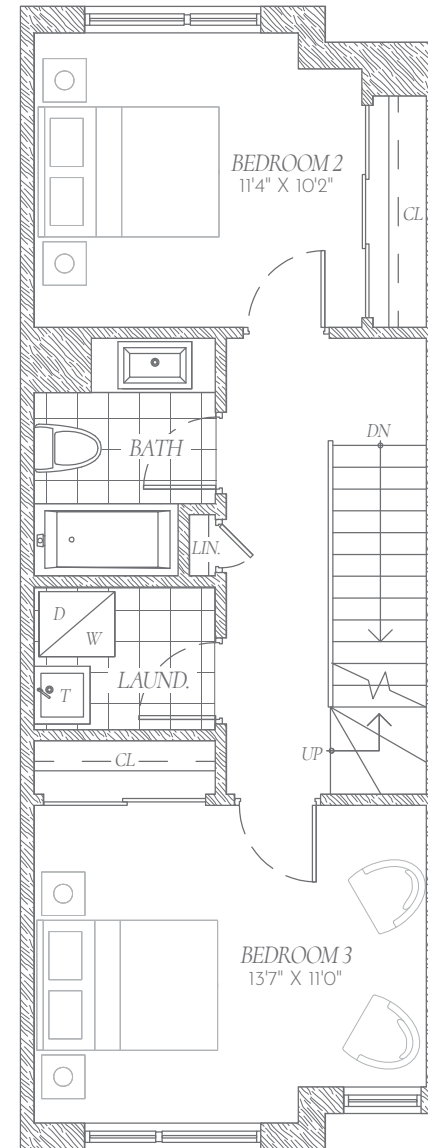

**SECOND FLOOR  
OPT. 1**

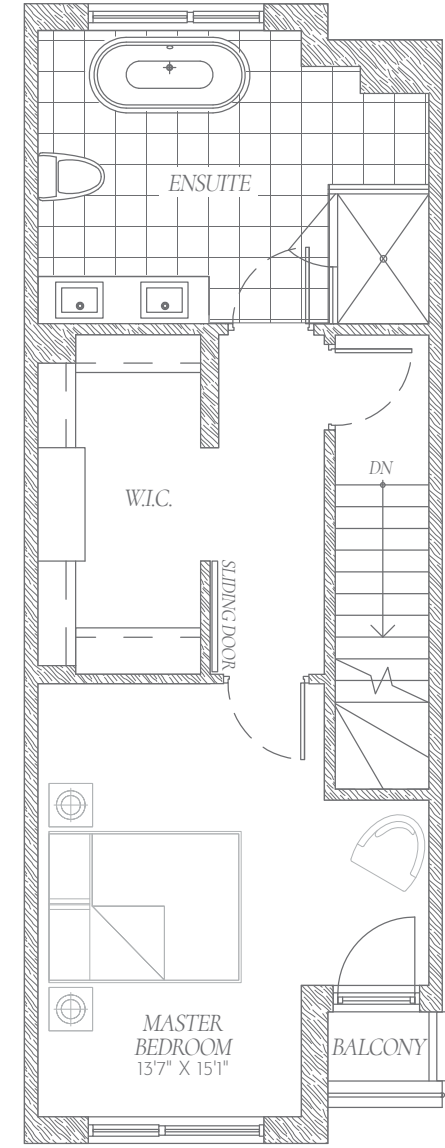

**THIRD FLOOR  
OPT. 1**

# THE HOUNDSTOOTH

## 1,722 SQ.FT.

STANDARD: MASTER BED - LEVEL 3

HOUNDSTOOTH END UNIT • 1,778 SQ.FT.  
HOUNDSTOOTH CORNER UNIT • 1,791 SQ.FT.



All floor plans, elevations and site plan are artist's concept only. Specifications and landscaping are subject to change without notice. Note that floor plan layouts and room dimensions may vary according to elevation. All backyards and driveways are conceptual only and are subject to actual POTL. Drawing is not to scale and all dimensions are approximate. Actual usable or space may vary from the stated floor area. Purchaser(s) acknowledge and agree to accept a reverse layout (mirror image) of all floor plans and elevations which the Developer or Municipality may require.

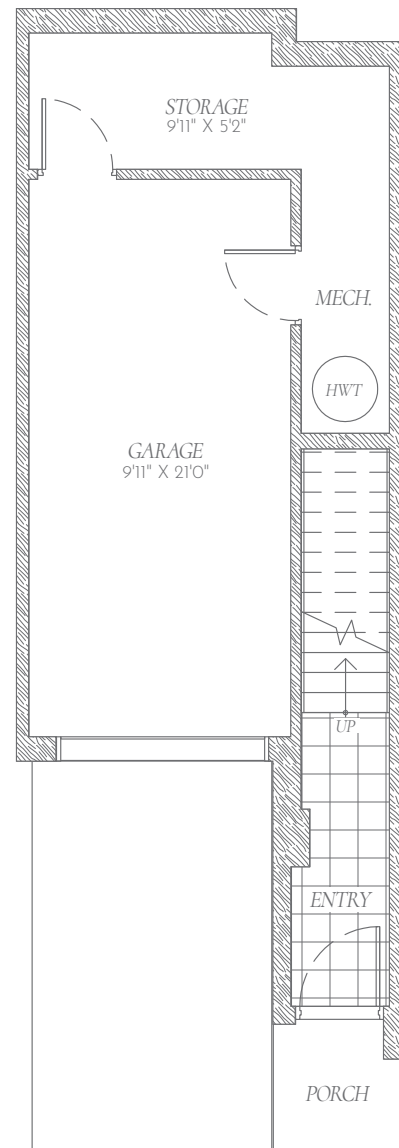

**BASEMENT**

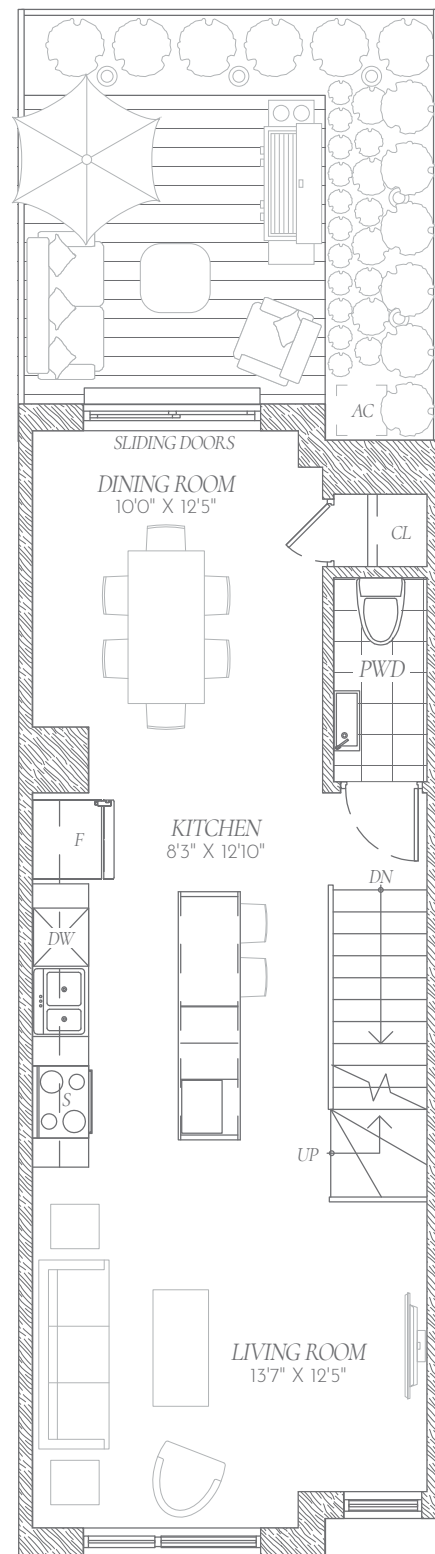

**FIRST FLOOR**

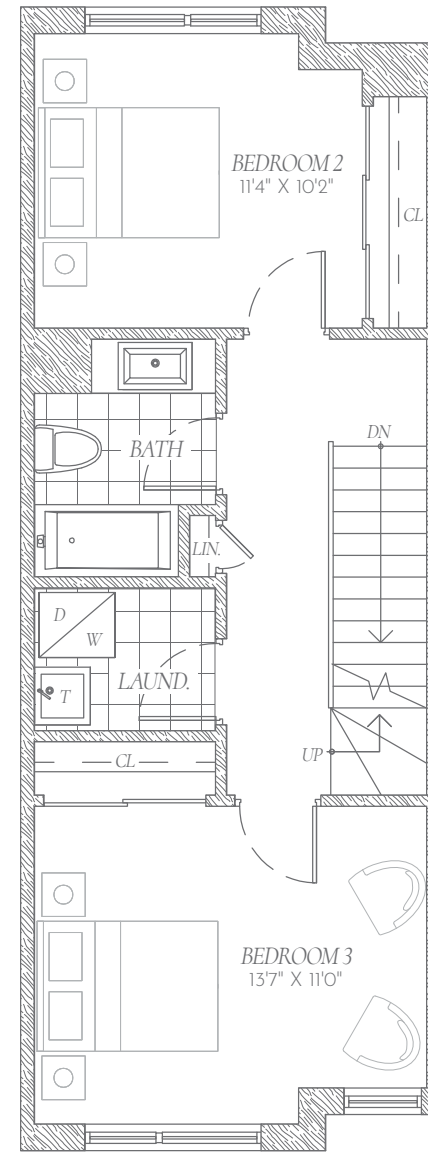

**SECOND FLOOR  
OPT. 2**

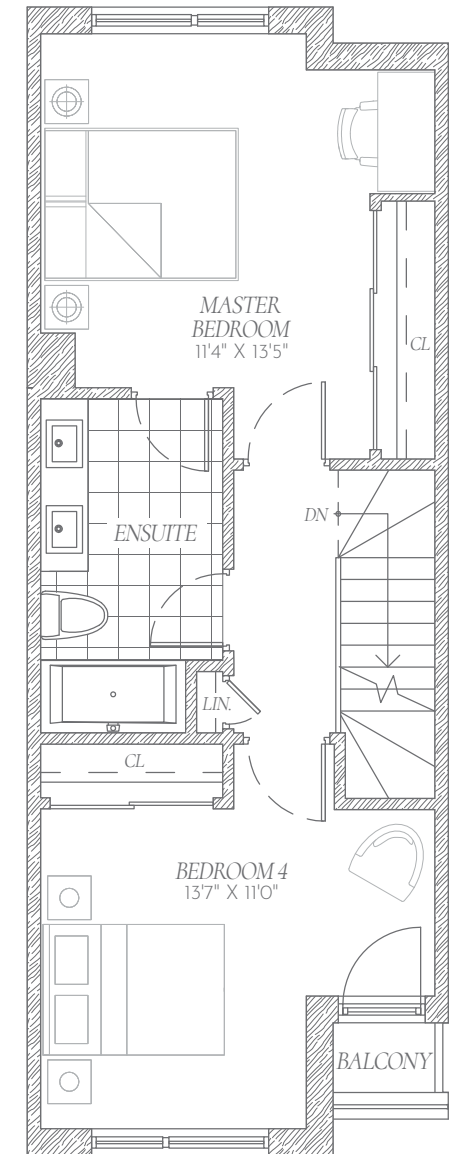

**THIRD FLOOR  
OPT. 2**

# THE HOUNDSTOOTH

UPGRADE: 4 BEDROOMS

## 1,722 SQ.FT.

HOUNDSTOOTH END UNIT • 1,778 SQ.FT.  
 HOUNDSTOOTH CORNER UNIT • 1,791 SQ.FT.



All floor plans, elevations and site plan are artist's concept only. Specifications and landscaping are subject to change without notice. Note that floor plan layouts and room dimensions may vary according to elevation. All backyards and driveways are conceptual only and are subject to actual POTL. Drawing is not to scale and all dimensions are approximate. Actual usable or space may vary from the stated floor area. Purchaser(s) acknowledge and agree to accept a reverse layout (mirror image) of all floor plans and elevations which the Developer or Municipality may require.



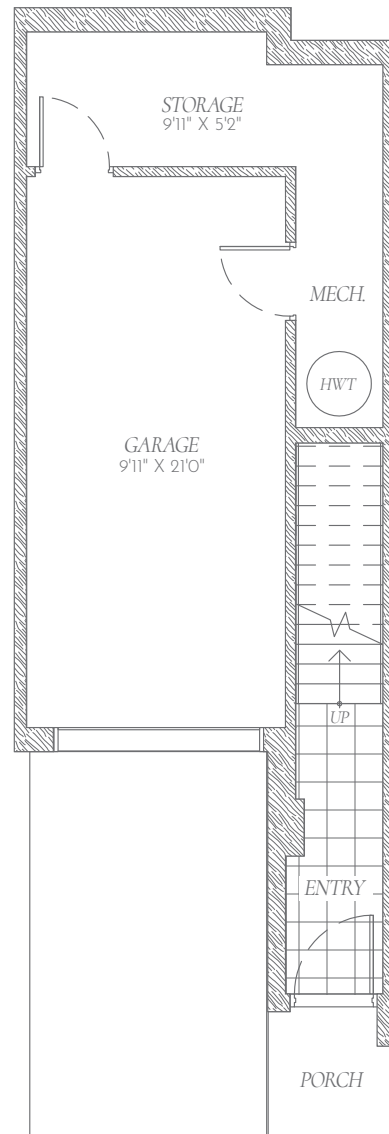

**BASEMENT**

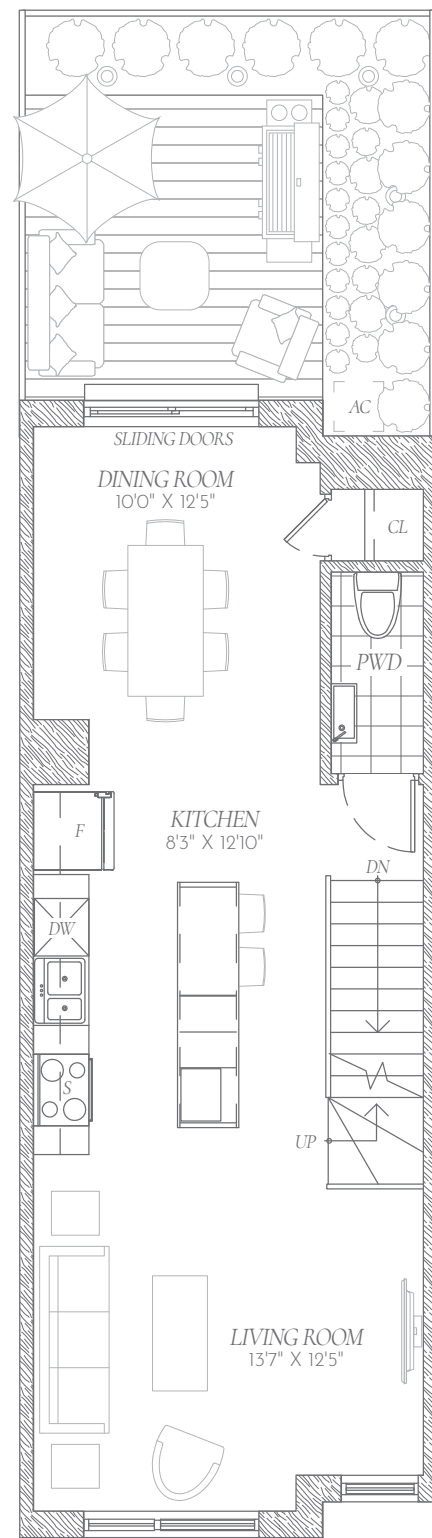

**FIRST FLOOR**

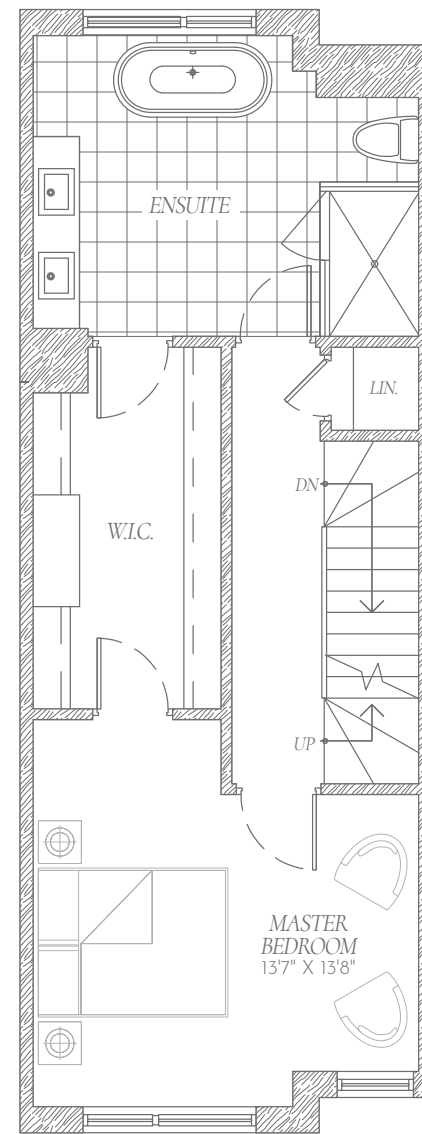

**SECOND FLOOR  
OPT. 3**

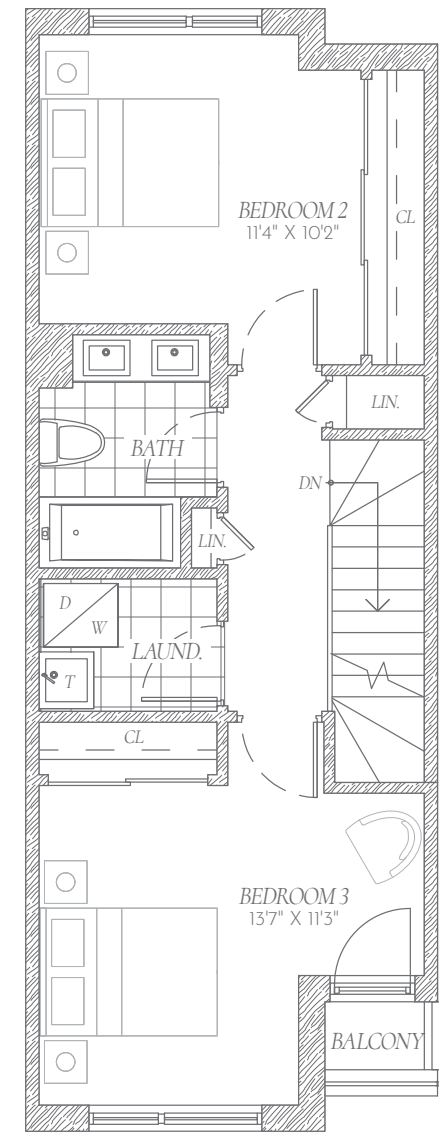

**THIRD FLOOR  
OPT. 3**

# THE HOUNDSTOOTH

## 1,722 SQ.FT.

UPGRADE: MASTER BED - LEVEL 2

HOUNDSTOOTH END UNIT • 1,778 SQ.FT.  
HOUNDSTOOTH CORNER UNIT • 1,791 SQ.FT.



All floor plans, elevations and site plan are artist's concept only. Specifications and landscaping are subject to change without notice. Note that floor plan layouts and room dimensions may vary according to elevation. All backyards and driveways are conceptual only and are subject to actual POTL. Drawing is not to scale and all dimensions are approximate. Actual usable or space may vary from the stated floor area. Purchaser(s) acknowledge and agree to accept a reverse layout (mirror image) of all floor plans and elevations which the Developer or Municipality may require.

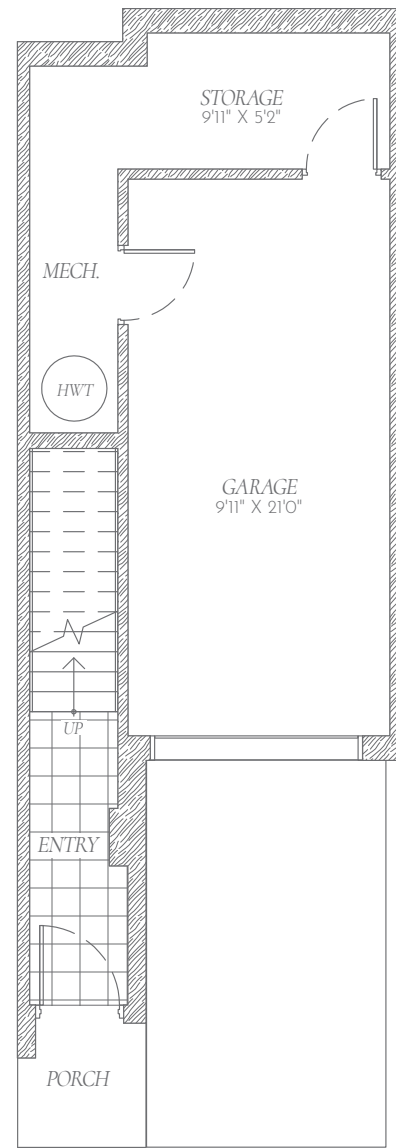

BASEMENT

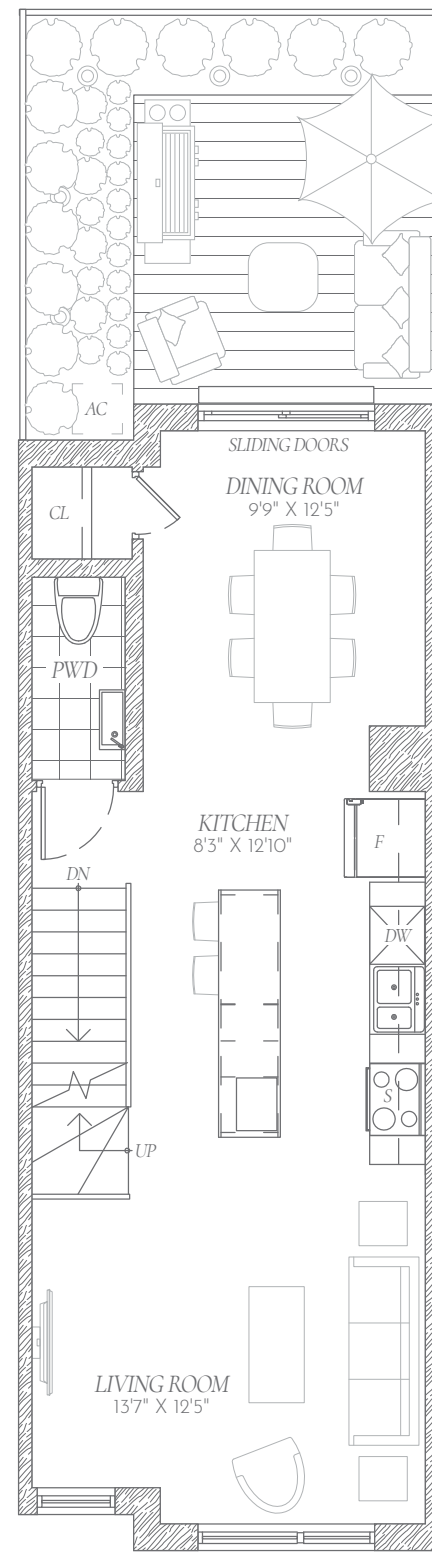

FIRST FLOOR

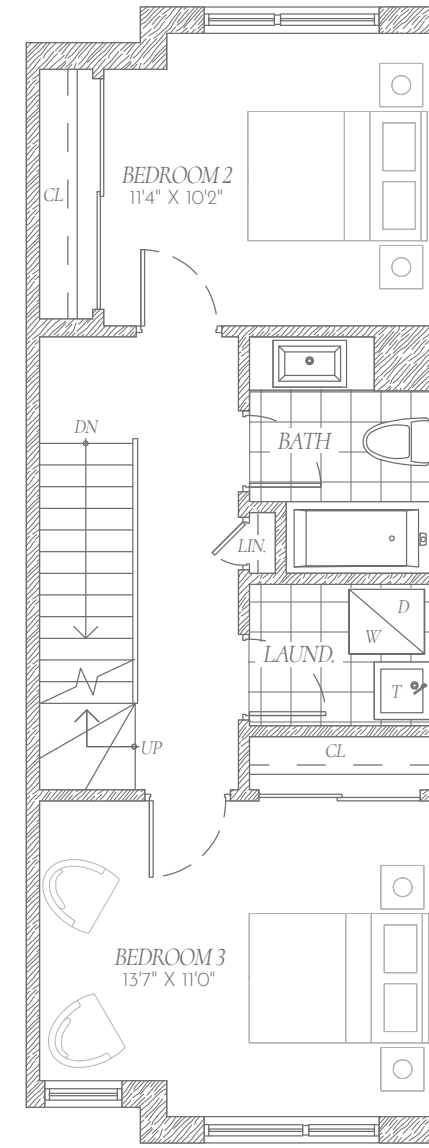

SECOND FLOOR  
OPT. 1

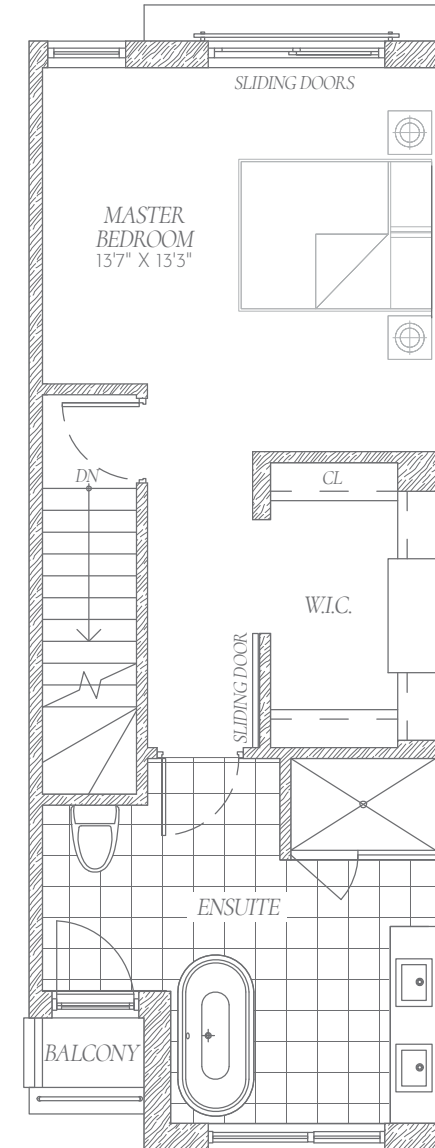

THIRD FLOOR  
OPT. 1

# THE HERRINGBONE

## 1,706 SQ.FT.

STANDARD: MASTER BED - LEVEL 3

HERRINGBONE END UNIT • 1,769 SQ.FT.  
HERRINGBONE CORNER UNIT • 1,764 SQ.FT.



All floor plans, elevations and site plan are artist's concept only. Specifications and landscaping are subject to change without notice. Note that floor plan layouts and room dimensions may vary according to elevation. All backyards and driveways are conceptual only and are subject to actual POTL. Drawing is not to scale and all dimensions are approximate. Actual usable or space may vary from the stated floor area. Purchaser(s) acknowledge and agree to accept a reverse layout (mirror image) of all floor plans and elevations which the Developer or Municipality may require.

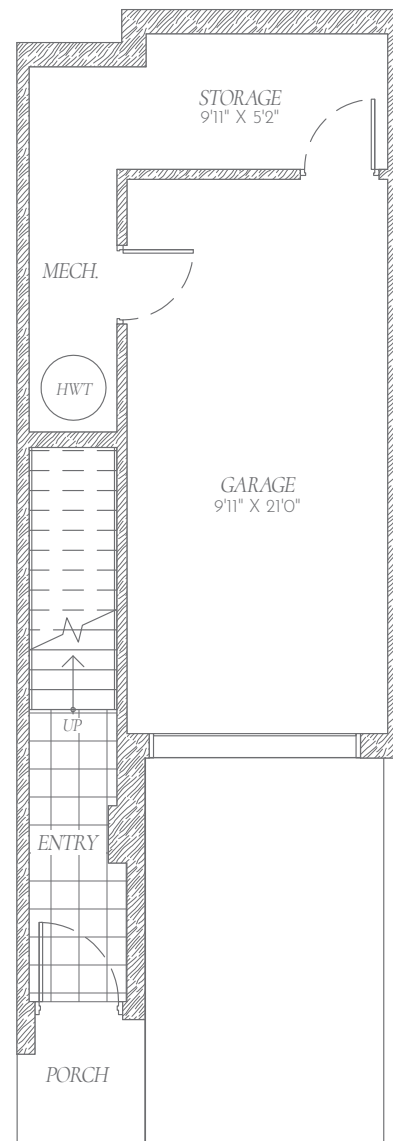

**BASEMENT**

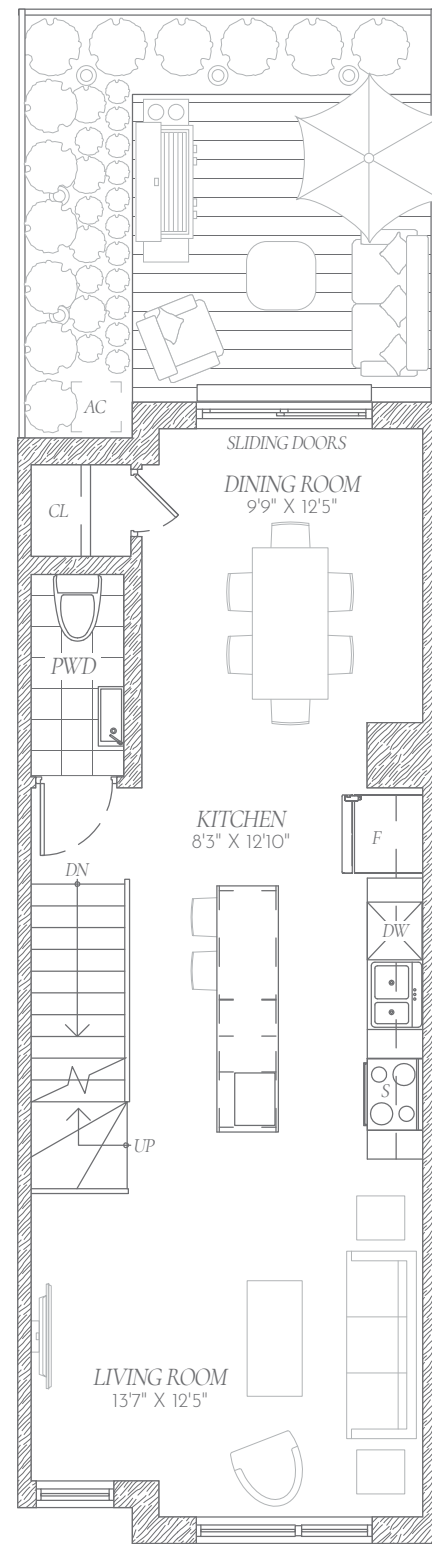

**FIRST FLOOR**

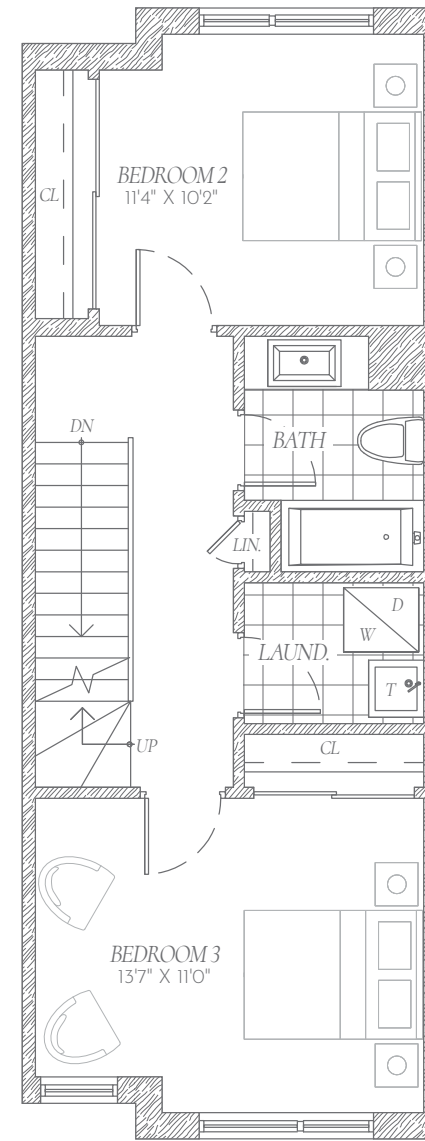

**SECOND FLOOR  
OPT. 2**

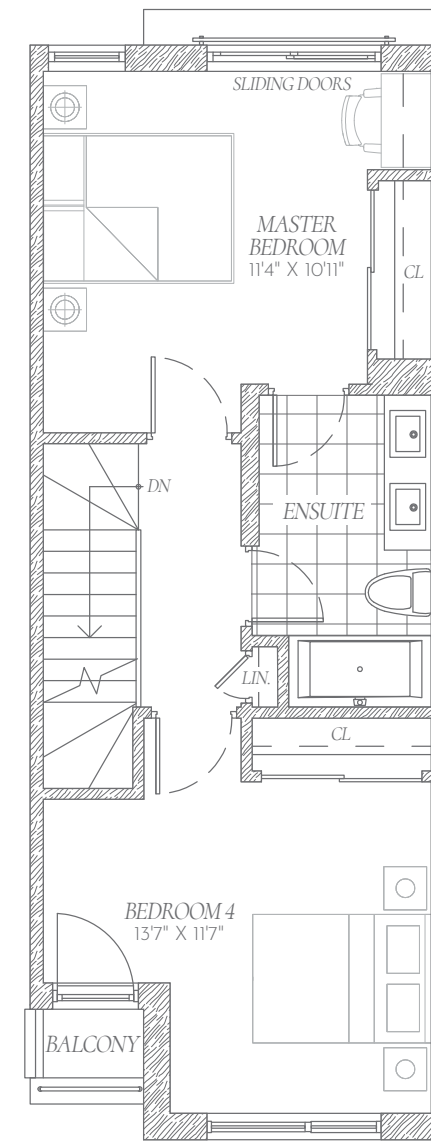

**THIRD FLOOR  
OPT. 2**

# THE HERRINGBONE

## 1,706 SQ.FT.

OPTION 2 UPGRADE: 4 BEDROOMS

HERRINGBONE END UNIT • 1,769 SQ.FT.  
HERRINGBONE CORNER UNIT • 1,764 SQ.FT.



All floor plans, elevations and site plan are artist's concept only. Specifications and landscaping are subject to change without notice. Note that floor plan layouts and room dimensions may vary according to elevation. All backyards and driveways are conceptual only and are subject to actual POTL. Drawing is not to scale and all dimensions are approximate. Actual usable or space may vary from the stated floor area. Purchaser(s) acknowledge and agree to accept a reverse layout (mirror image) of all floor plans and elevations which the Developer or Municipality may require.

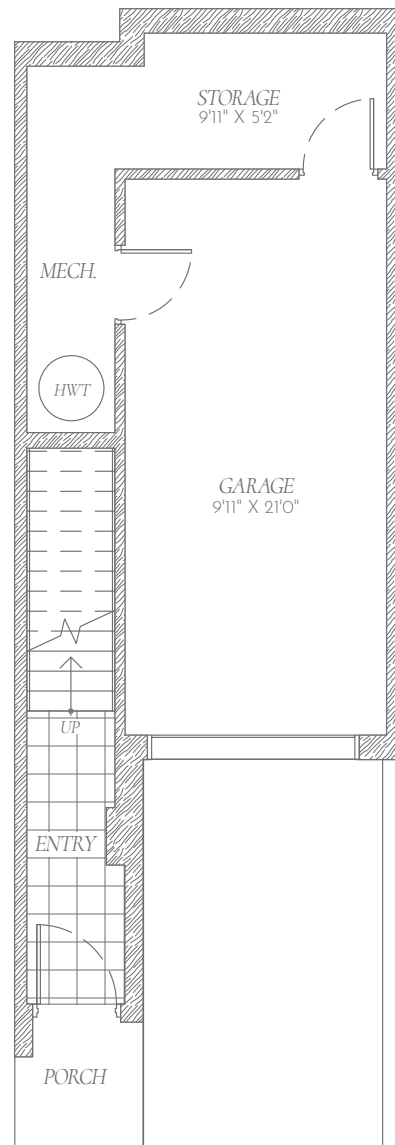

**BASEMENT**

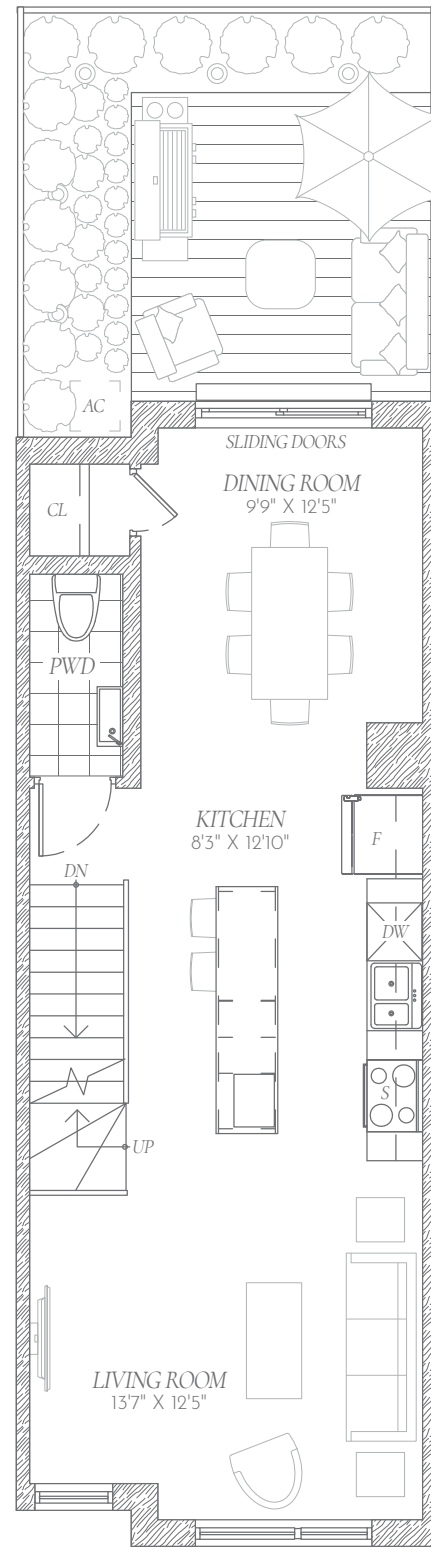

**FIRST FLOOR**

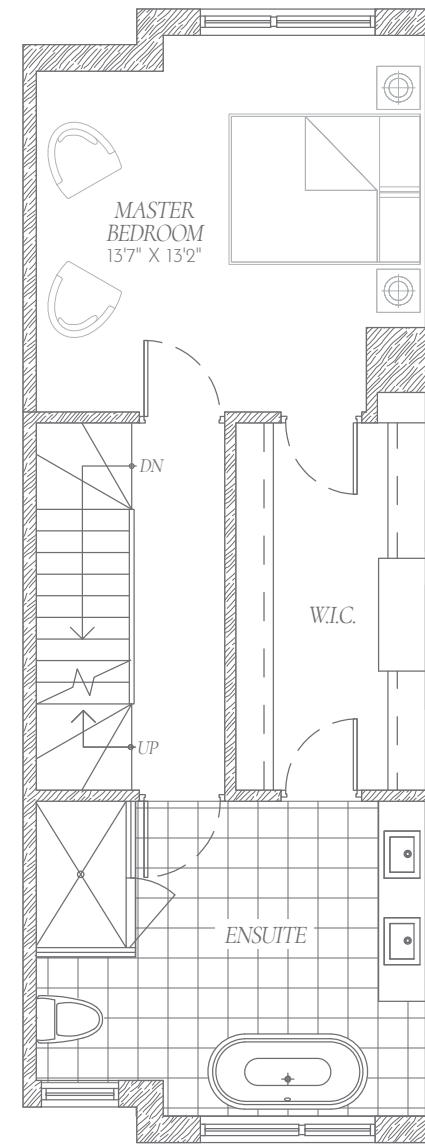

**SECOND FLOOR  
OPT. 3**

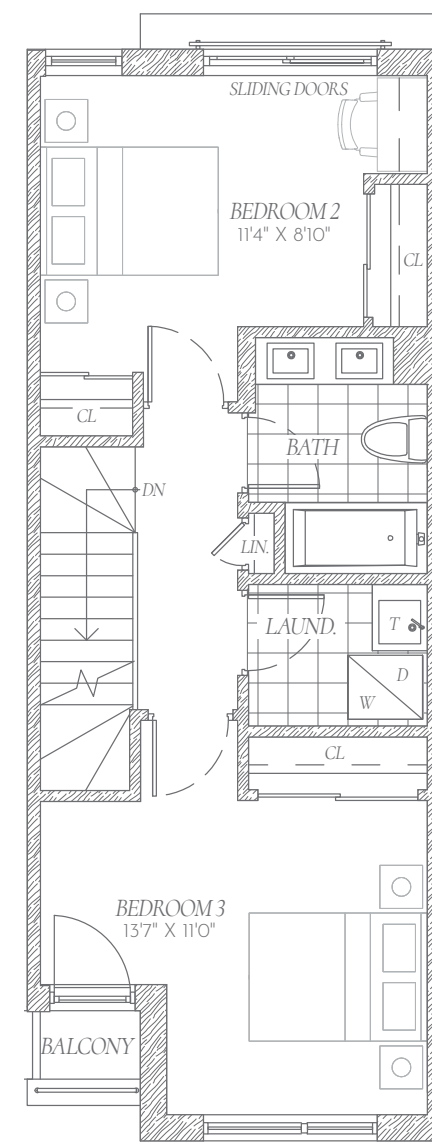

**THIRD FLOOR  
OPT. 3**

# THE HERRINGBONE

## 1,706 SQ.FT.

OPTION 3 UPGRADE: MASTER BED - LEVEL 2



HERRINGBONE END UNIT • 1,769 SQ.FT.  
HERRINGBONE CORNER UNIT • 1,764 SQ.FT.

All floor plans, elevations and site plan are artist's concept only. Specifications and landscaping are subject to change without notice. Note that floor plan layouts and room dimensions may vary according to elevation. All backyards and driveways are conceptual only and are subject to actual POTL. Drawing is not to scale and all dimensions are approximate. Actual usable or space may vary from the stated floor area. Purchaser(s) acknowledge and agree to accept a reverse layout (mirror image) of all floor plans and elevations which the Developer or Municipality may require.

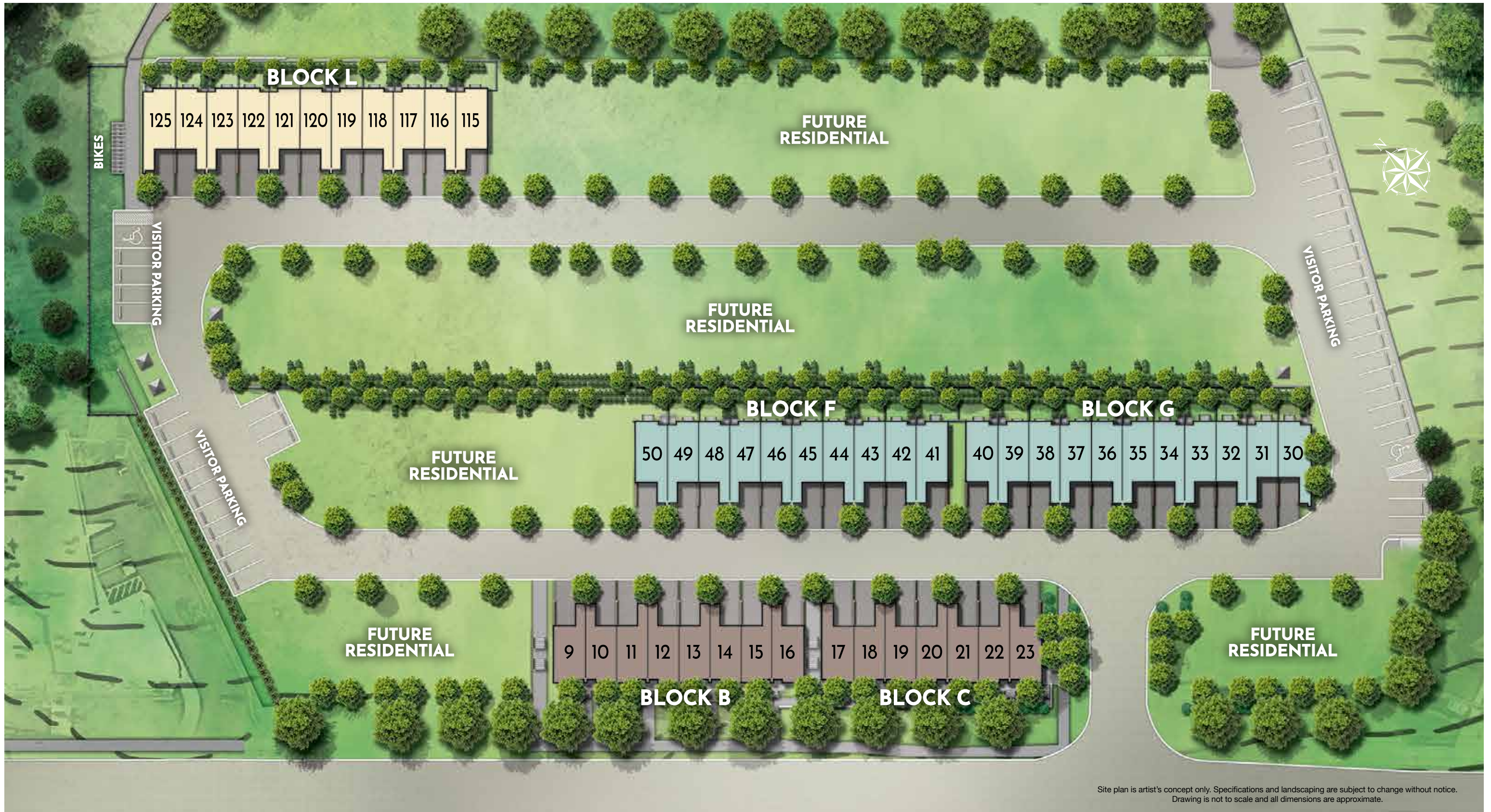

# THE SITE PLAN



- THE TWEED
- THE HOUNDSTOOTH
- THE HERRINGBONE