

# DTK condos

 suites  
**podium**

**A LIMITED COLLECTION OF SUITES**

Live life elevated here at DTK Condos.

The Podium Suites are a series of residences that are located on the grand podium levels on the 2nd through 4th floors.

Each suite is bathed in natural light and offers expansive views from impressive floor-to-ceiling windows.

631

ONE BEDROOM + DEN

SUITE 1E: 573 SQ.FT. BALCONY: 58 SQ.FT. TOTAL: 631 SQ.FT.

dtk  
condos

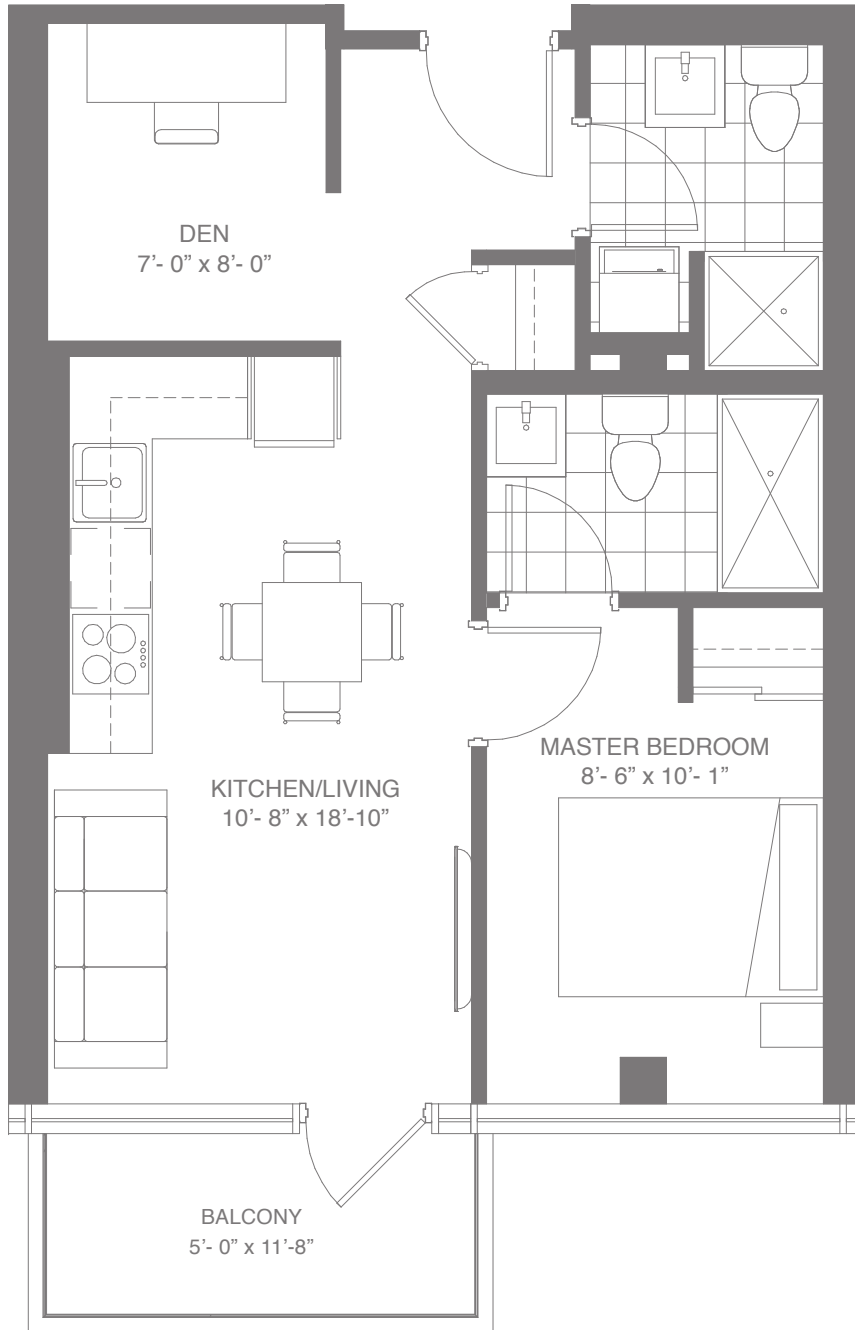

SUITE LOCATION

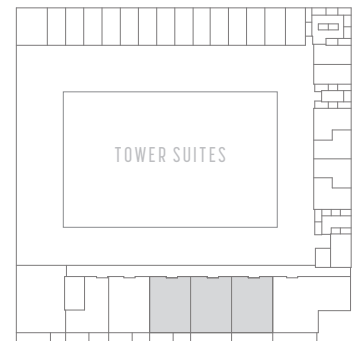

Plans and specifications are subject to change without notice. Actual usable floor space may vary from stated floor area. Illustrations are artists concept only and may show optional features not included in base price. See sales representative for further information. E. & O. E.

631

ONE BEDROOM + DEN

SUITE 1F: 573 SQ.FT. BALCONY: 58 SQ.FT. TOTAL: 631 SQ.FT.

dtk  
condos

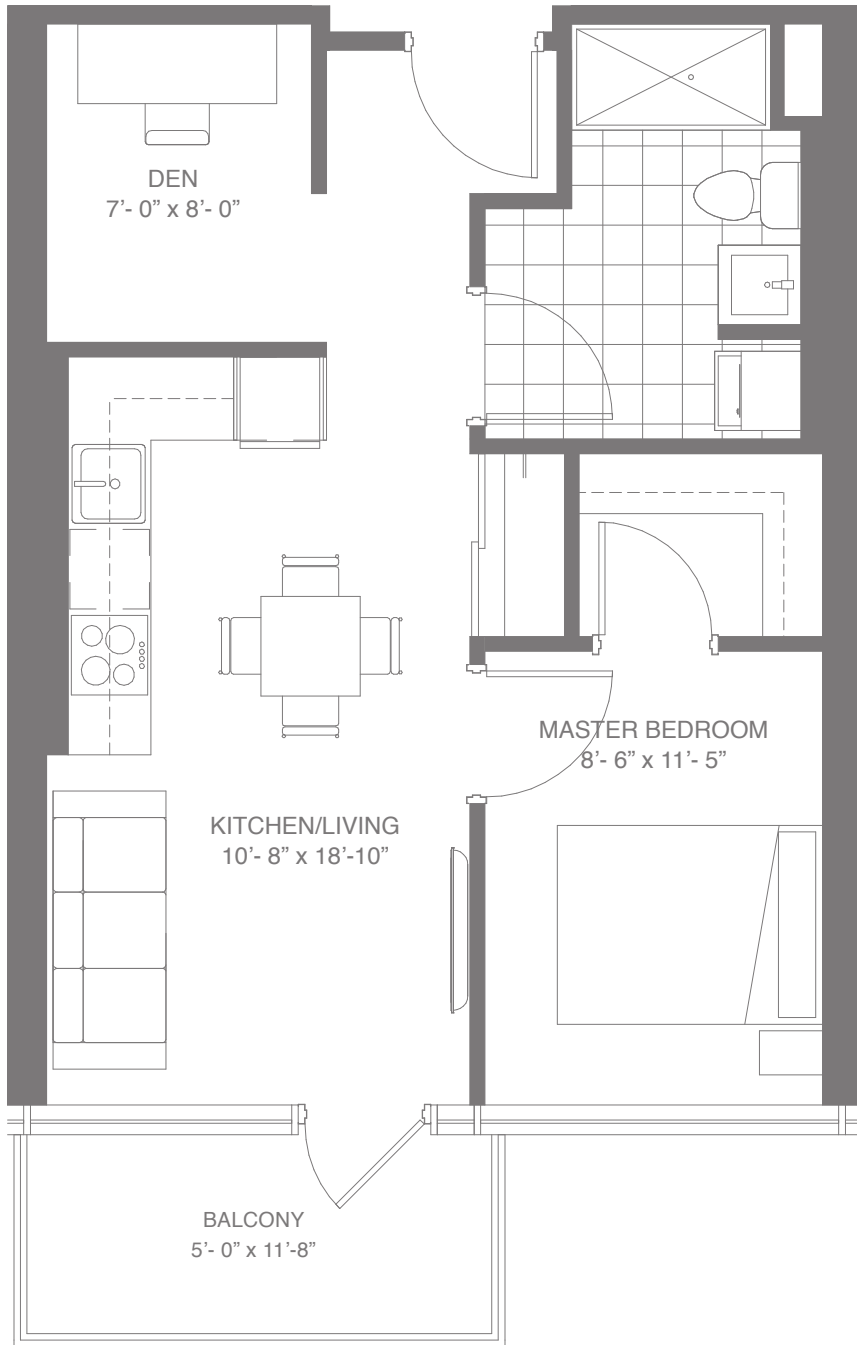

SUITE LOCATION

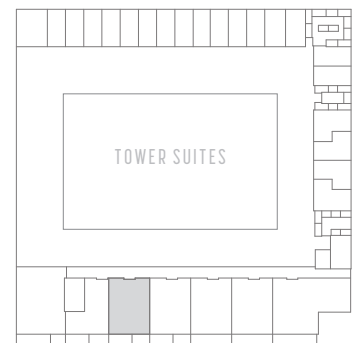

DUKE STREET EAST

FREDERICK STREET

Plans and specifications are subject to change without notice. Actual usable floor space may vary from stated floor area. Illustrations are artists concept only and may show optional features not included in base price. See sales representative for further information. E. & O. E.

502

ONE BEDROOM

SUITE 1G: 444 SQ.FT. BALCONY: 58 SQ.FT. TOTAL: 502 SQ.FT.

dtk  
condos

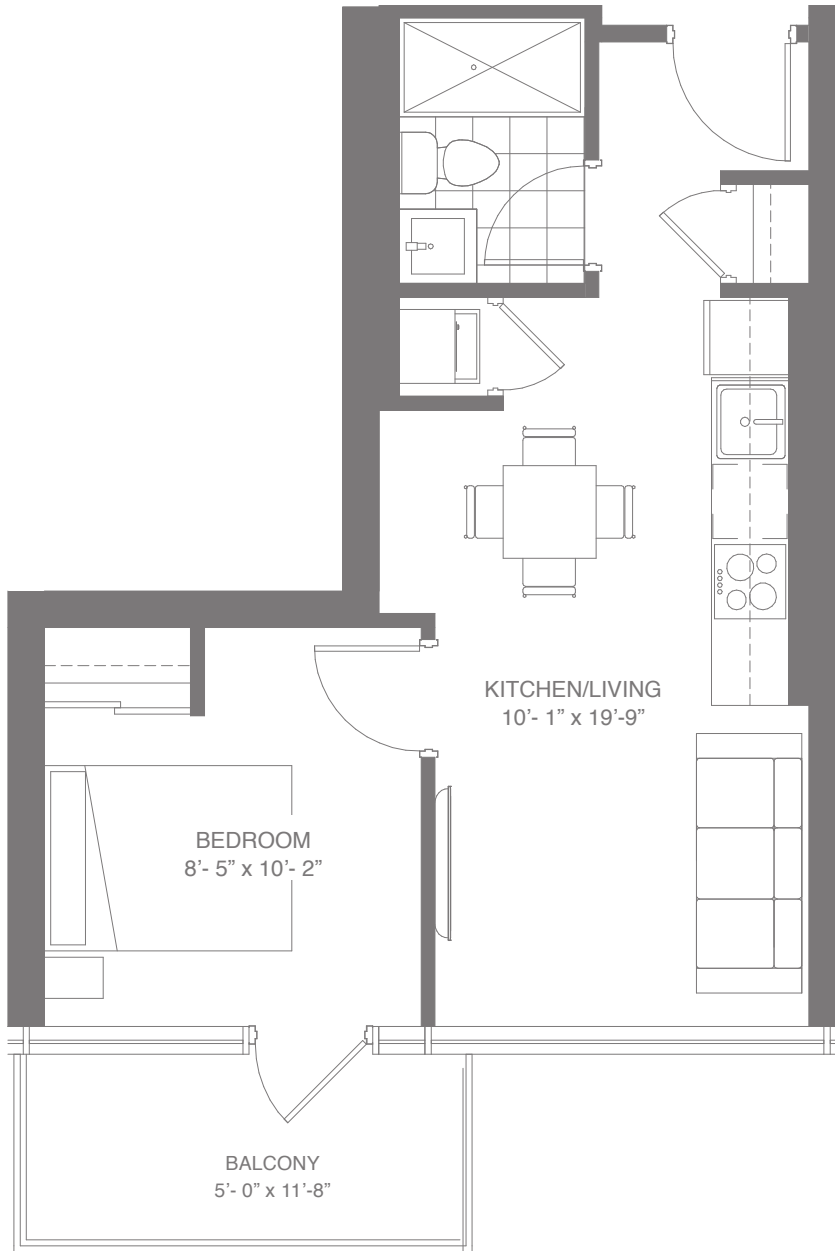

SUITE LOCATION

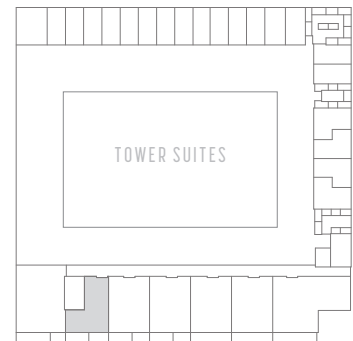

DUKE STREET EAST →

FREDERICK STREET

Plans and specifications are subject to change without notice. Actual usable floor space may vary from stated floor area. Illustrations are artists concept only and may show optional features not included in base price. See sales representative for further information. E. & O. E.

908

TWO BEDROOMS

SUITE 2D: 823 SQ.FT. BALCONY: 85 SQ.FT. TOTAL: 908 SQ.FT.

dtk  
condos

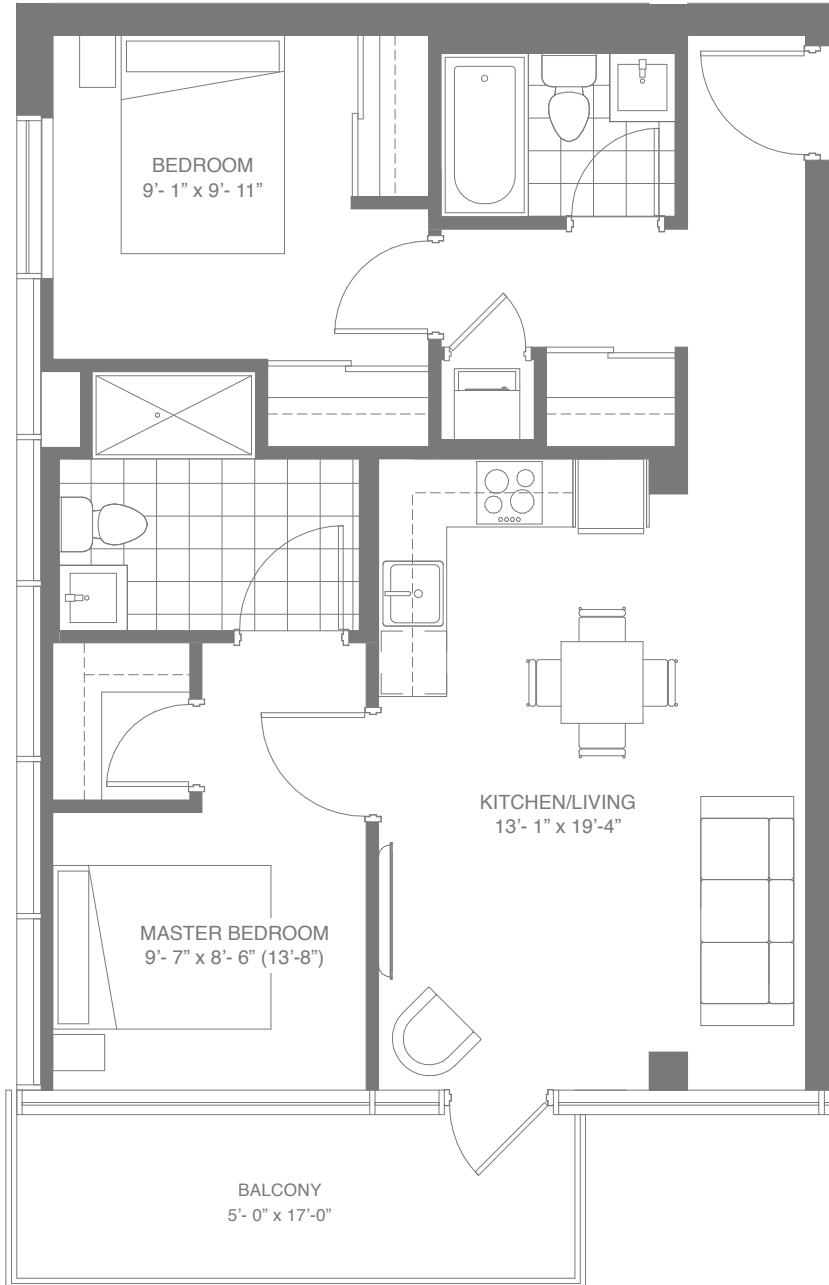

SUITE LOCATION

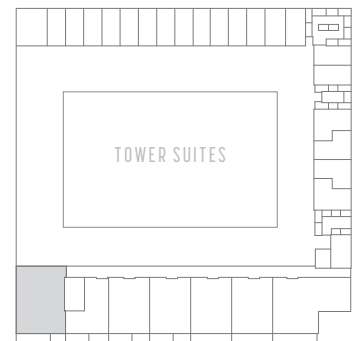

DUKE STREET EAST

FREDERICK STREET

Plans and specifications are subject to change without notice. Actual usable floor space may vary from stated floor area. Illustrations are artists' concept only and may show optional features not included in base price. See sales representative for further information. E. & O. E.

1030

TWO BEDROOMS + DEN

SUITE 2E: 914 SQ.FT. BALCONY: 116 SQ.FT. TOTAL: 1030 SQ.FT.

dtk  
condos

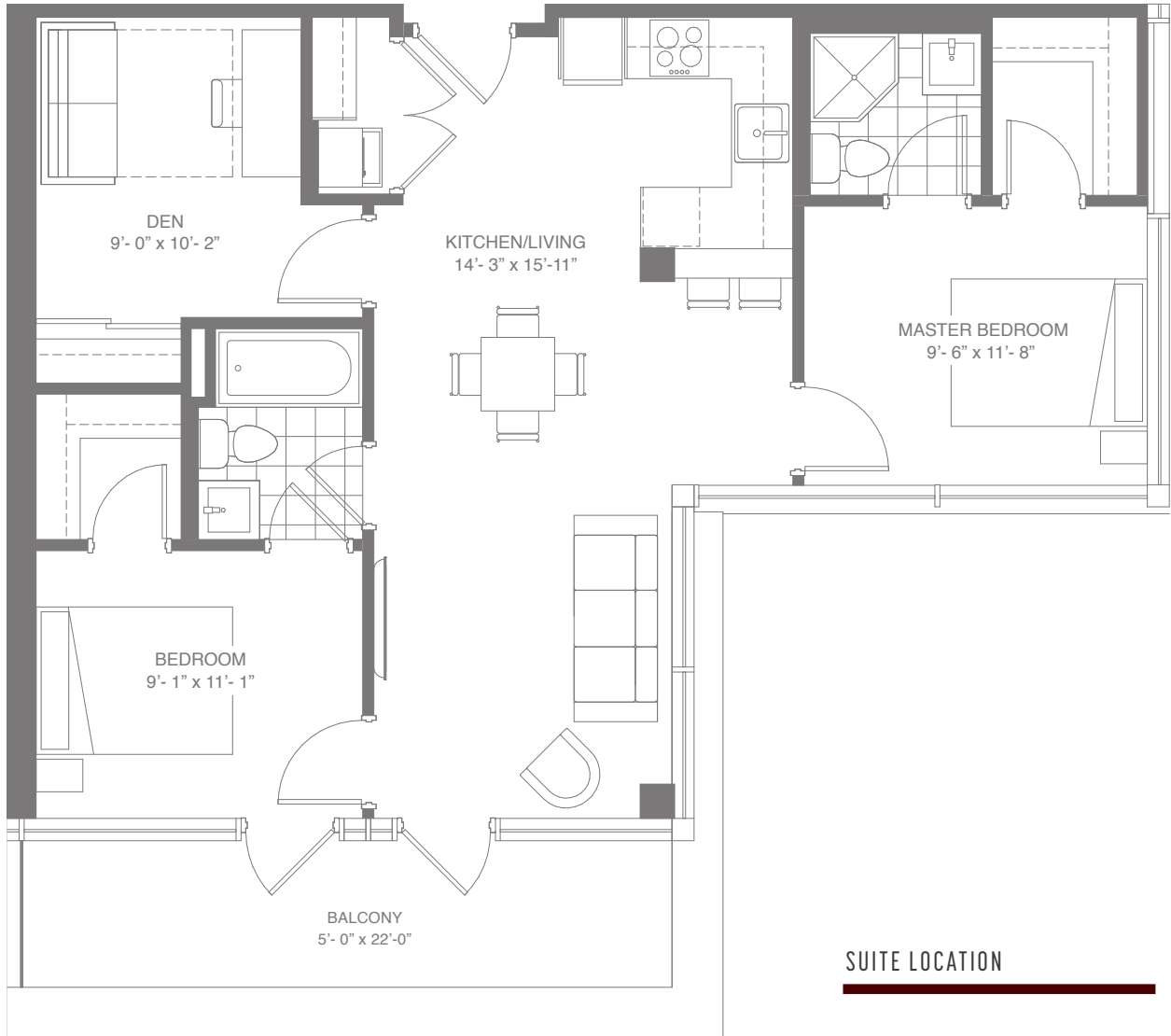

SUITE LOCATION

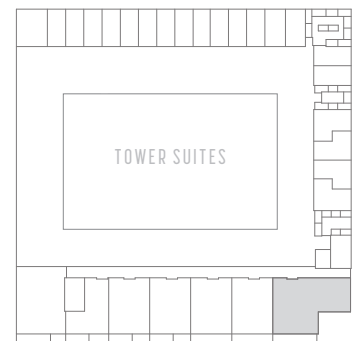

DUKE STREET EAST

FREDERICK STREET

Plans and specifications are subject to change without notice. Actual usable floor space may vary from stated floor area. Illustrations are artists concept only and may show optional features not included in base price. See sales representative for further information. E. & O. E.

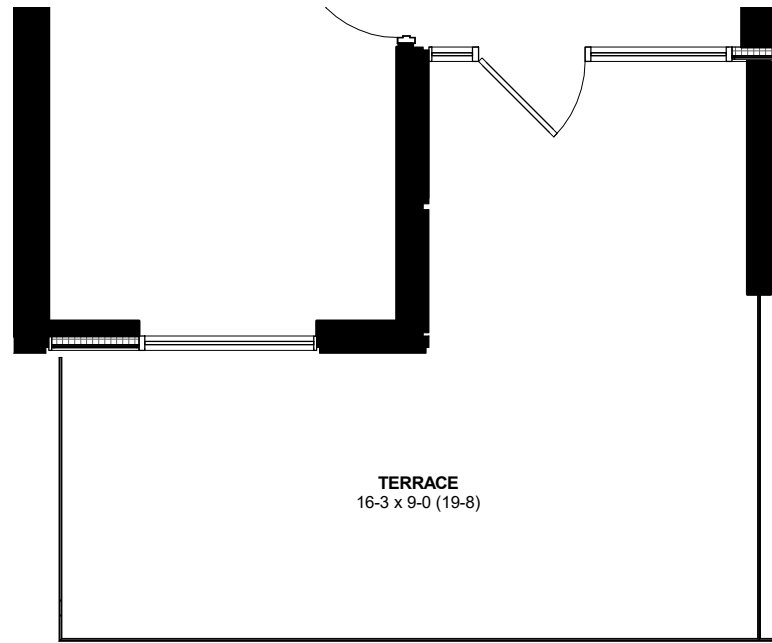

UNITS: 610, 611

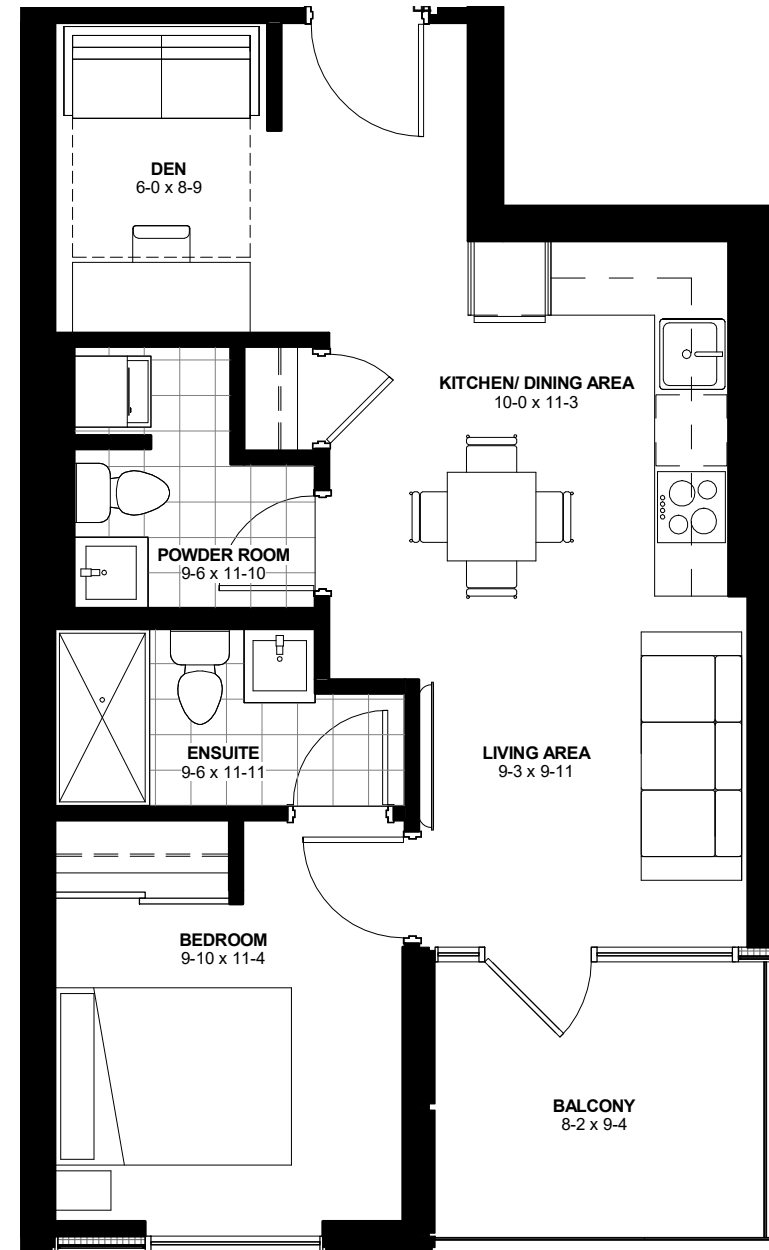

UNIT TYPE 1A

588 SF

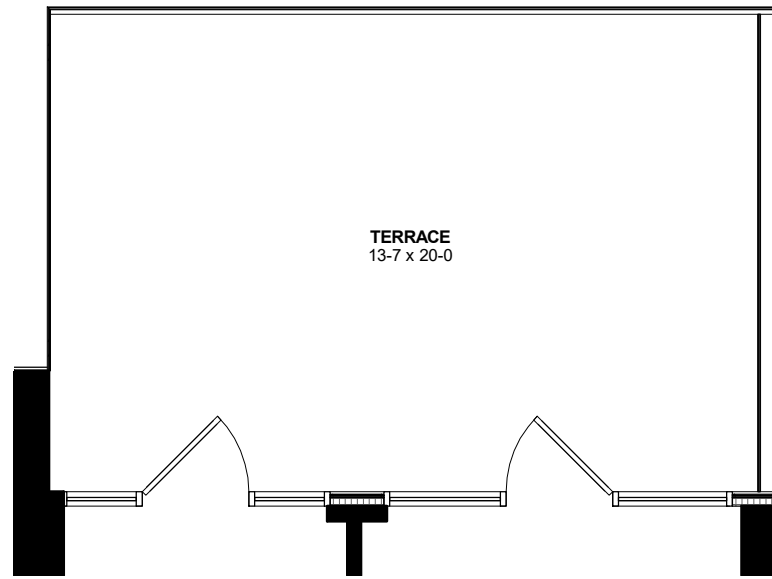

UNITS: 603, 606

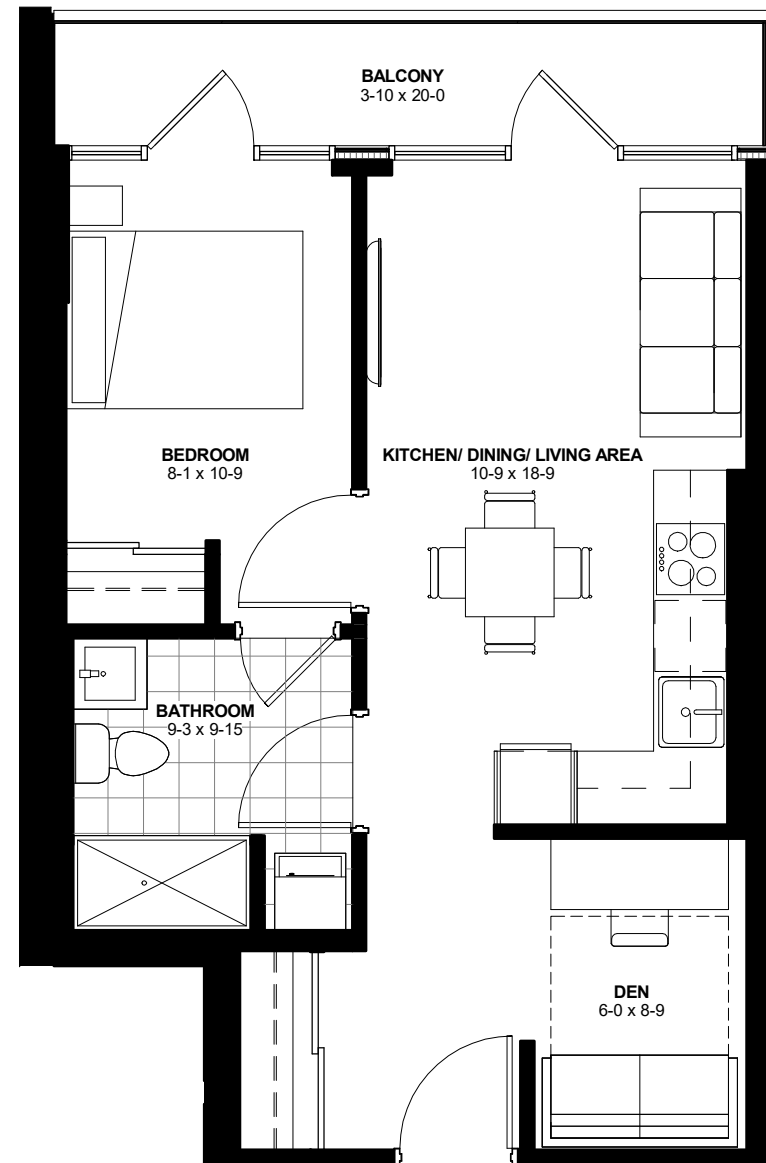

**UNIT TYPE 1B**

**555 SF**



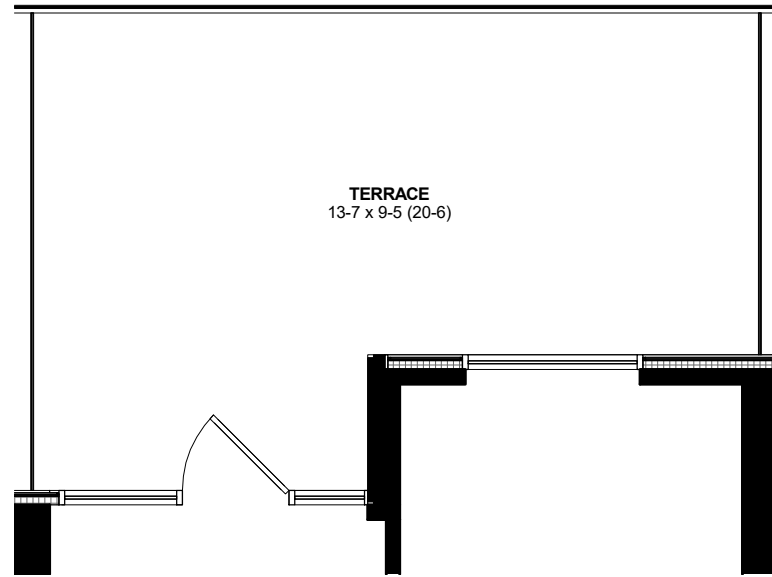

UNITS: 604, 605

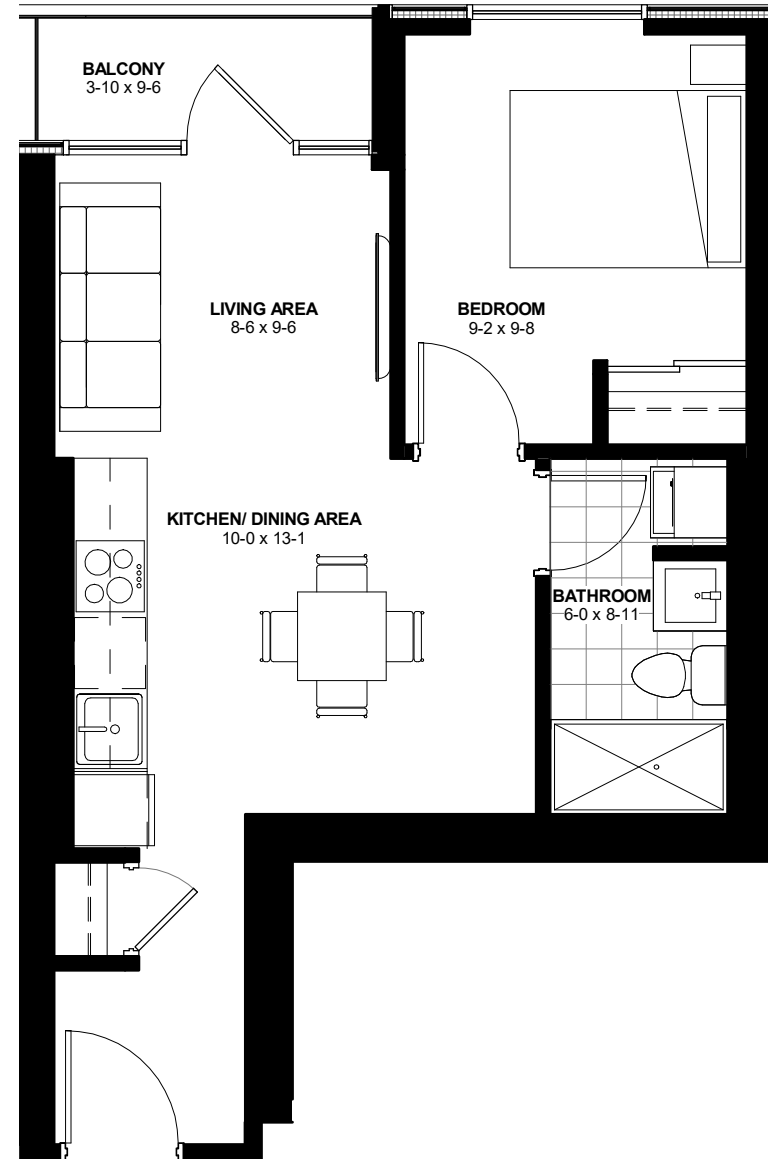

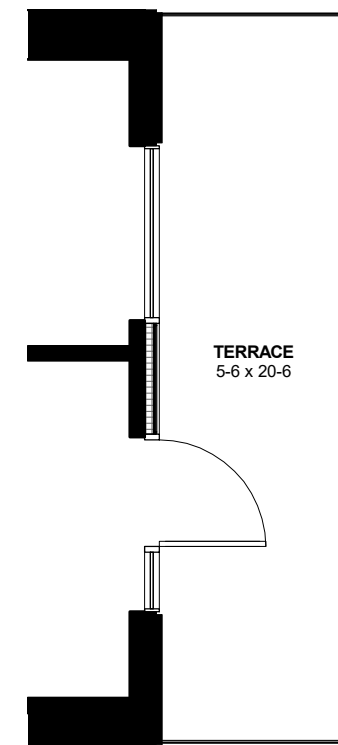

UNITS: 601, 608

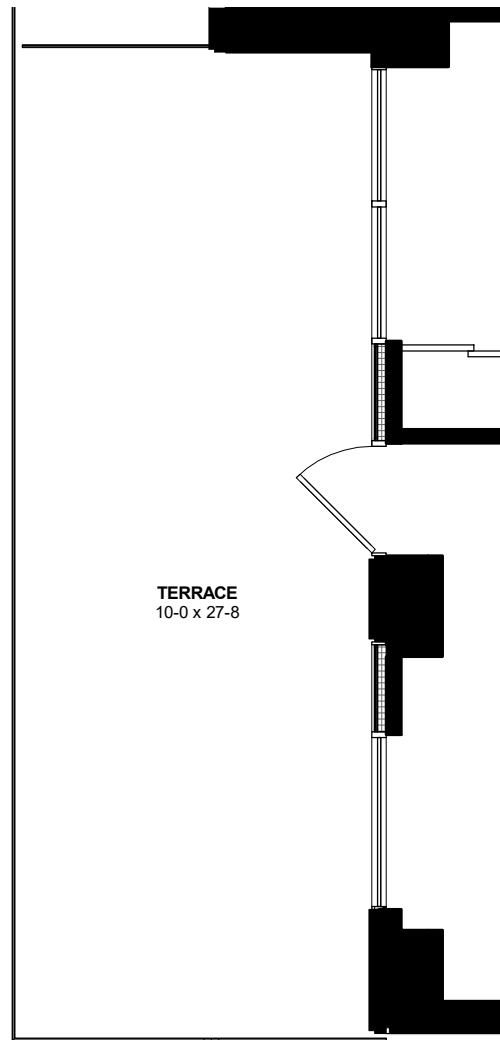

UNITS: 602, 609

**UNIT TYPE 2A**

**690 SF**

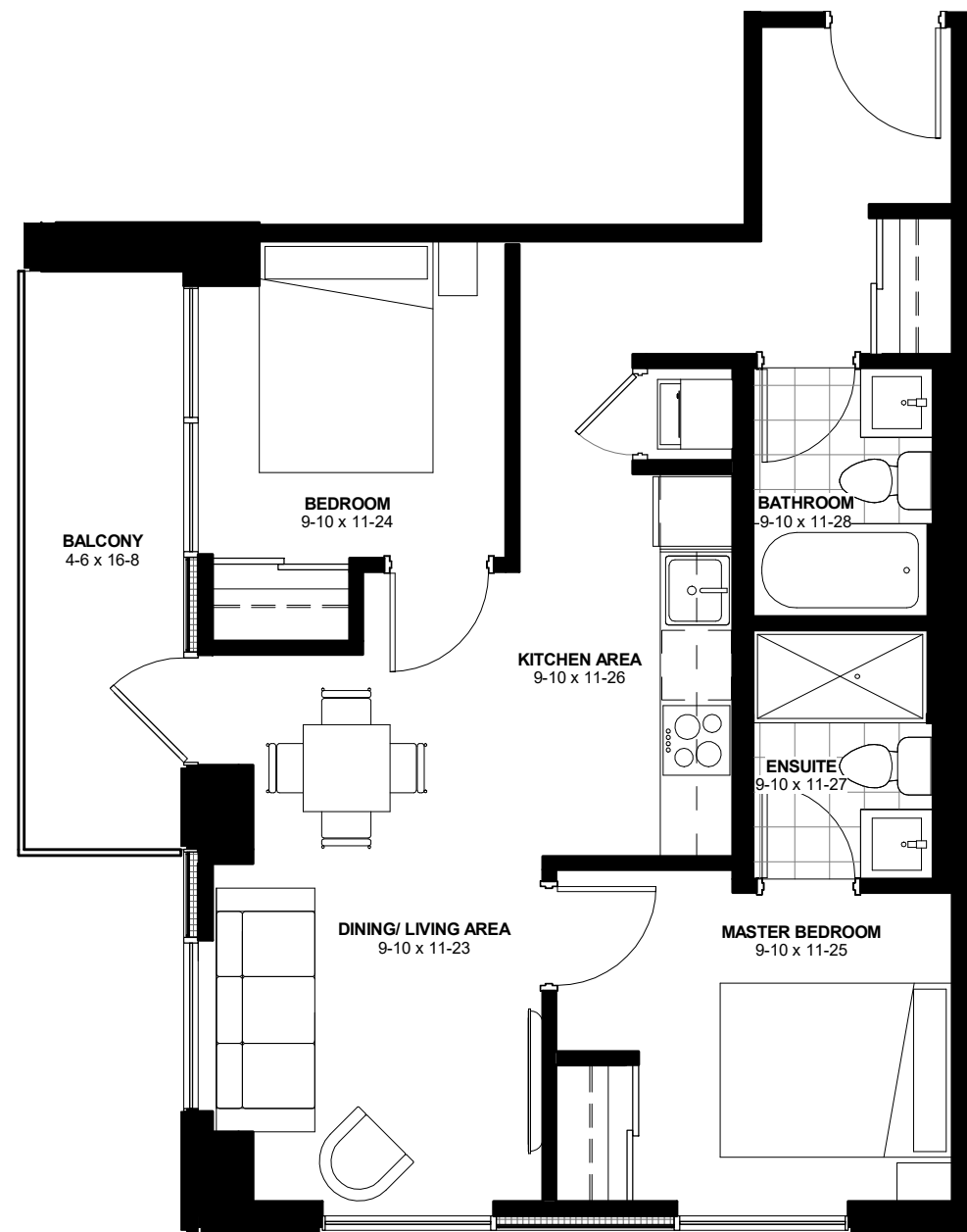

UNITS: 702  
802  
902  
1002, 1009  
1102, 1109  
1202, 1209  
1302, 1309  
1402, 1409  
1502, 1509

UNITS: 1602, 1609  
1702, 1709  
1802, 1809  
1902, 1909  
2002, 2009  
2102, 2109  
2202, 2209  
2302, 2309  
2402, 2409

UNITS: 2502, 2509  
2602, 2609  
2702, 2709  
2802, 2809  
2902, 2909  
3002, 3009  
3102, 3109  
3202  
3302

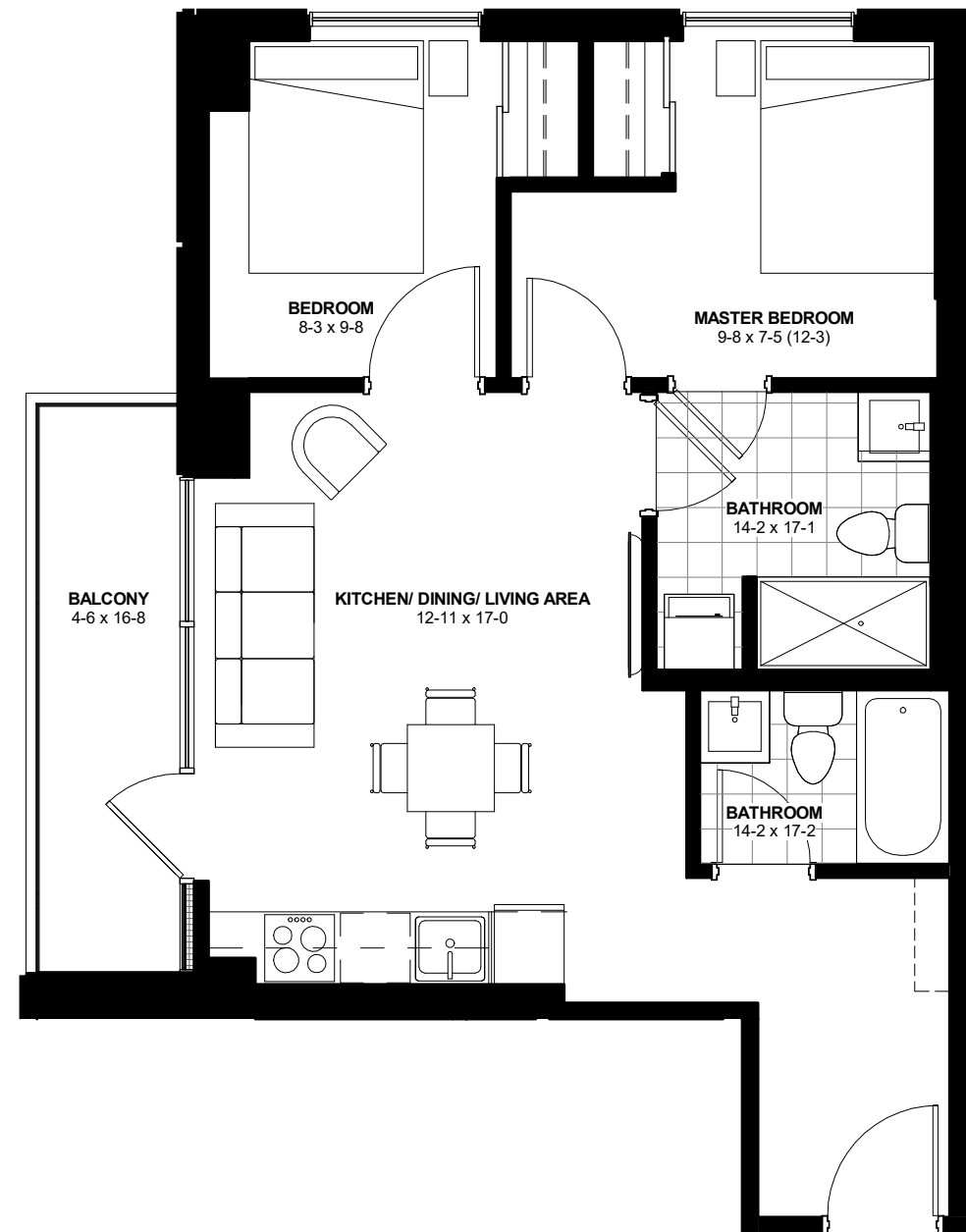
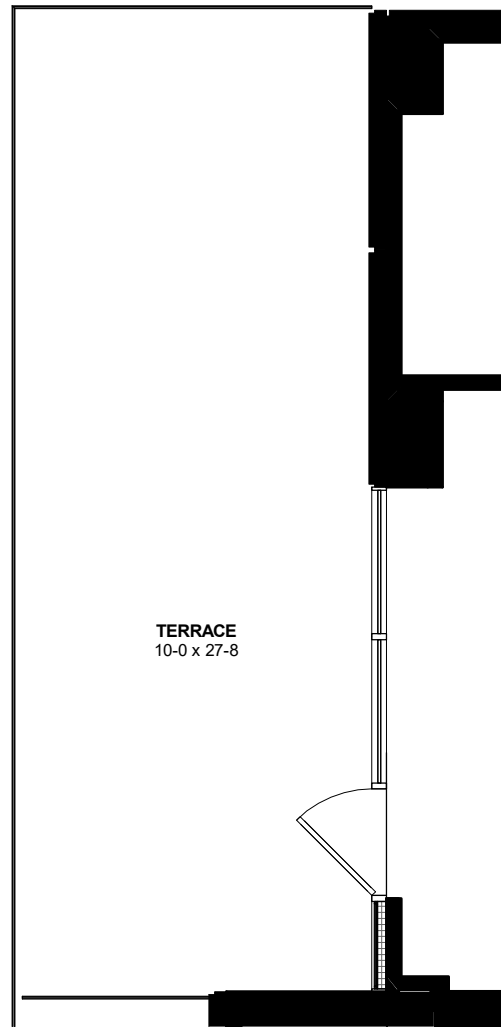

UNITS: 607

UNIT TYPE 2C

690 SF